

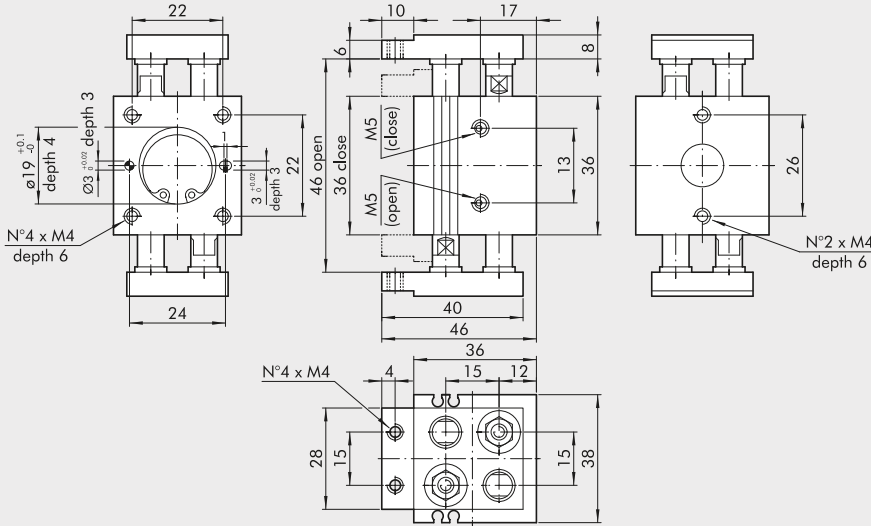

COTES D'ENCOMBREMENT PINCE P4-10

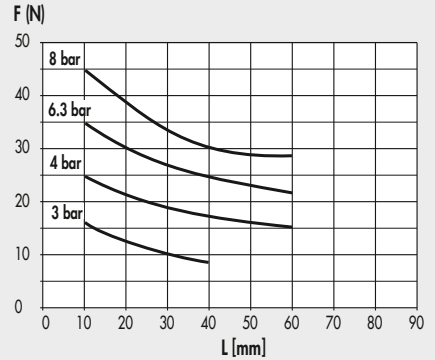

Code **W1580100200** Désignation **Pince à grande ouverture parallèle P4-10**



COTES D'ENCOMBREMENT P4-12

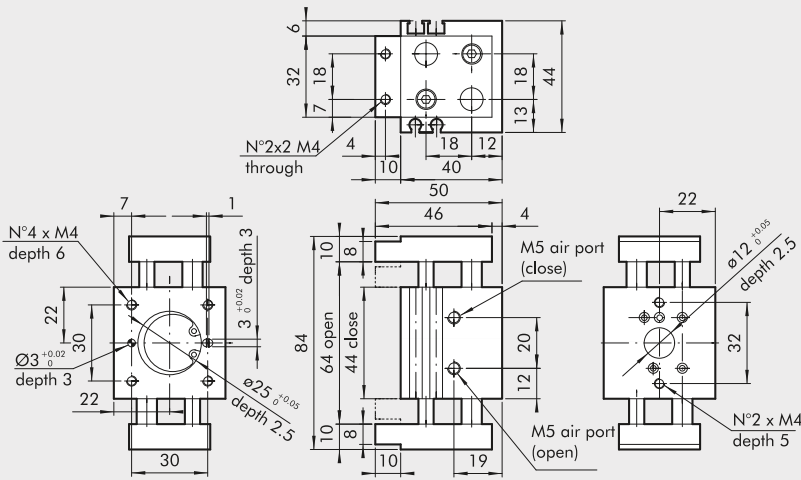

Code **W1580120200** Désignation **Pince à grande ouverture parallèle P4-12**

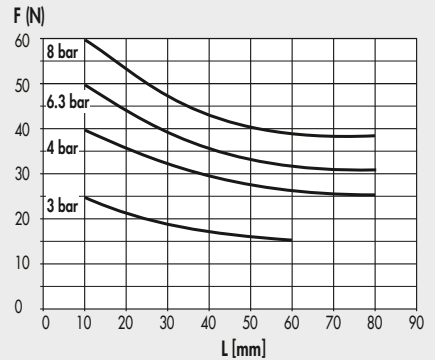

COTES D'ENCOMBREMENT P4-16

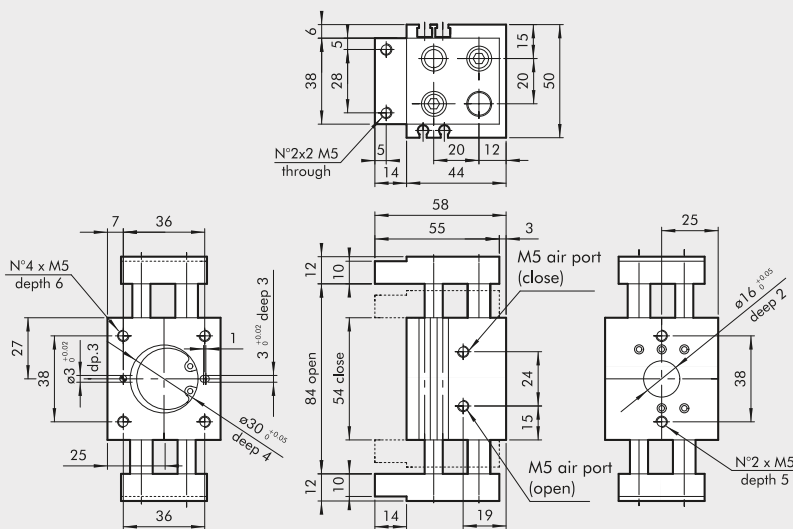

Code **W1580160200** Désignation **Pince à grande ouverture parallèle P4-16**

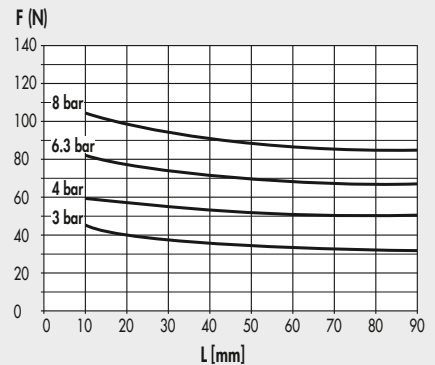

**COTES D'ENCOMBREMENT P4-25**

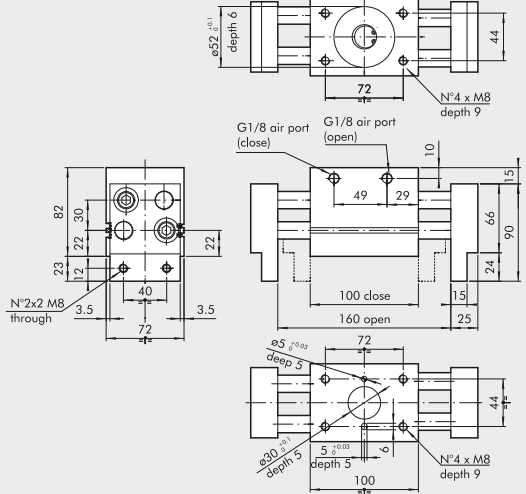

**Code** W1580250200 **Désignation** Pince à grande ouverture parallèle P4-25

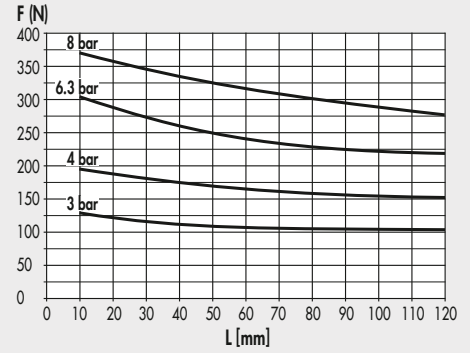

**COTES D'ENCOMBREMENT P4-30**

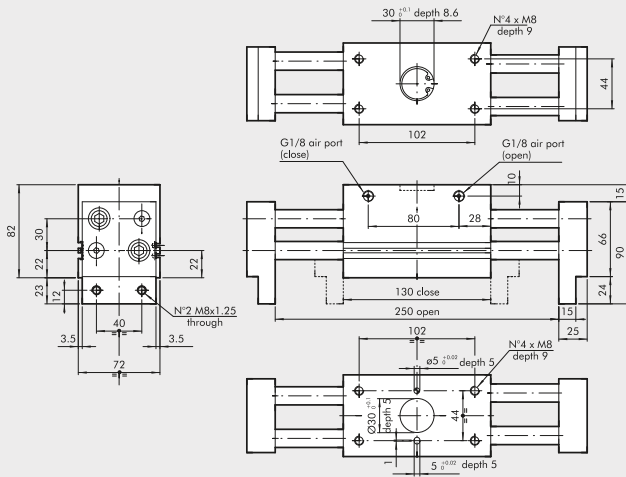

**Code** W1580300200 **Désignation** Pince à grande ouverture parallèle P4-30

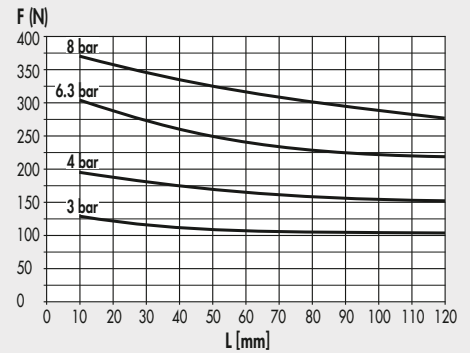

**ACCESSOIRES**

**UNITES DE DETECTION MAGNETIQUE Ø 4 mm**

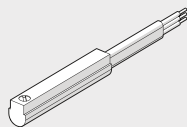

Pour la codification et les caractéristiques techniques, voir le chapitre A6.

**UNITES DE DETECTION A INSERTION VERTICALE**

**UNITE DE DETECTION, TYPE CARRE**  
De dernière génération,  
fixation sécurisée

**UNITE DE DETECTION, TYPE OVALE**  
Traditionnelle

Pour la codification et les caractéristiques techniques, voir le chapitre A6.

