

**BES 12,0-KB-5-F  
BAM00CH**

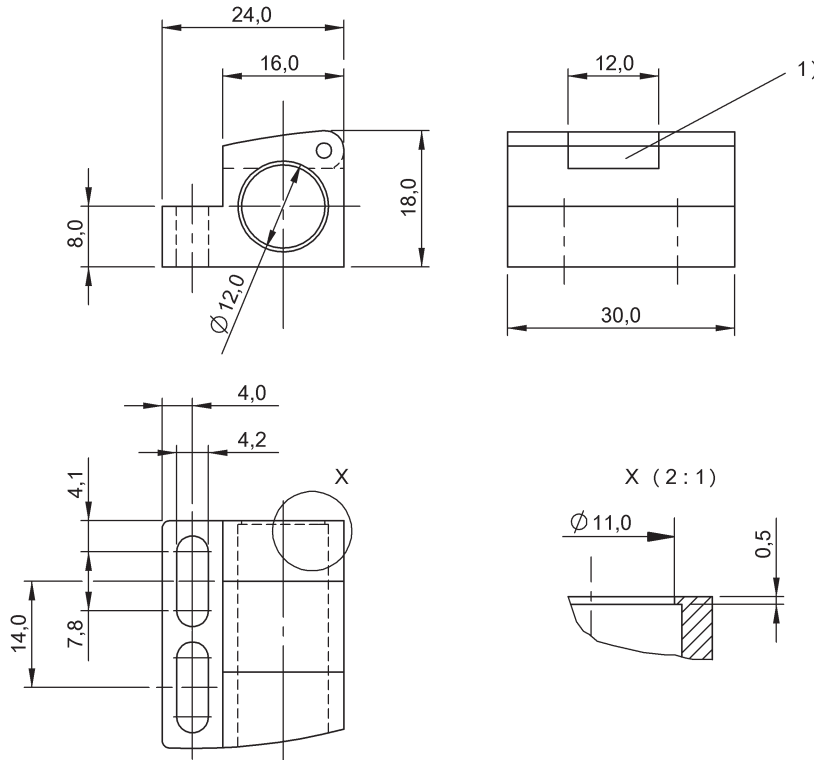

L

1) Locking system mechanical

- Mounting clamp
- Clamping pedestal
- Use with sensors Ø12mm and M12
- PC

**General attributes**

Application Use with sensors Ø12mm and M12

**Electrical attributes**

**Mechanical attributes**

Length 1 30.0 mm  
Length 2 24.0 mm

Length 3

Material 18.0 mm  
Mounting type PC  
Version Clamping  
Clamping pedestal

**Additional text**

The proximity switch is inserted into the clamp holder up to the fixed stop and secured with the clamping lever.