

# IN-LINE FLOW MICRO-REGULATOR SERIES RFL L

The RFL L flow micro-regulator belongs to the LINE ON LINE® family and can be connected in series or in parallel with all the other products. The RFL L regulates the air input and thus the speed in pneumatic actuators. Two versions are available:

**Type U (unidirectional)** regulates the flow only in one of the two directions of air flow. The following types of fitting can be mounted:

- Push-in input and output fitting
- Push-in input fitting and threaded port on the exhaust (cylinder type)
- Input threaded port and push-in fitting on the exhaust (valve type)

**Type B (bidirectional)** regulates the flow in both directions of air flow.

The following types of fitting can be mounted:

- Push-in input and output fitting
- Threaded port and push-in fitting

There are four possible types of assembly (see example below).



TECHNICAL DATA		Ø 4	Ø 6	Ø 8
Max. operating pressure	MPa		1	
	bar		10	
	psi		145	
Temperature range	°C		- 20 to + 60	
	°F		- 4 to + 140	
Max flow rate on regulation at 6.3 bar	Nl/min	155	450	850
Flow rate on exhaust at 6.3 bar	Nl/min	160	550	950
Adjustment		Manual or using a screwdriver		
Internal system		Tapered needle		
Recommended pipe		Rilsan PA 11 - Nylon 6 - Polyamide 12 - Polypropylene		
Fluid		Lubricated or unlubricated filtered air		
Compatibility with oils		Please refer to page 6-7 of the technical documentation		

## COMPONENTS

- ① Technopolymer body
- ② Nickel-plated brass seal support
- ③ NBR gasket
- ④ Brass adjusting needle
- ⑤ Nickel-plated brass needle ring nut
- ⑥ Wall fixing ring nut
- ⑦ NBR seal
- ⑧ Technopolymer spring ring
- ⑨ Stainless steel clip-on spring
- ⑩ Technopolymer stop bushing
- ⑪ Technopolymer release bushing

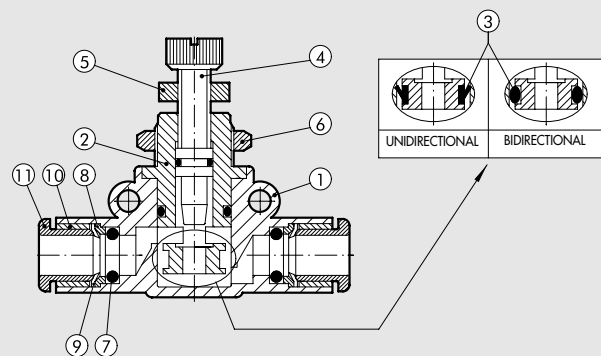

## ASSEMBLY OPTIONS

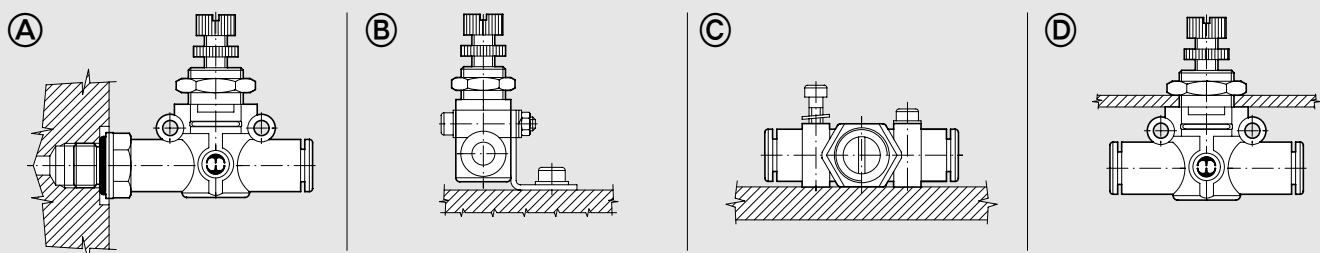

How to mount the RFL L:

- Fig. A With the male threaded port it is possible to mount the RFL L straight onto the actuator or the control valve.
- Fig. B Fixing to the plate with the special SQU L bracket.
- Fig. C There are two robust rings on the plastic body for fixing the RFL L straight onto the wall.
- Fig. D The ring nut is screwed onto the threaded metal part of the RFL L body for panel mounting.

**FLOW RATE CHARTS AT 6.3 bar DEPENDING ON THE TURNS EFFECTED BY THE REGULATION SCREW**

RFL L Ø 4

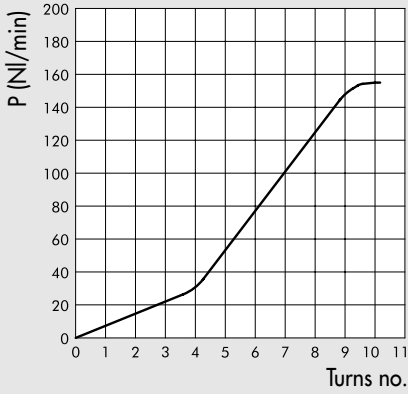

RFL L Ø 6

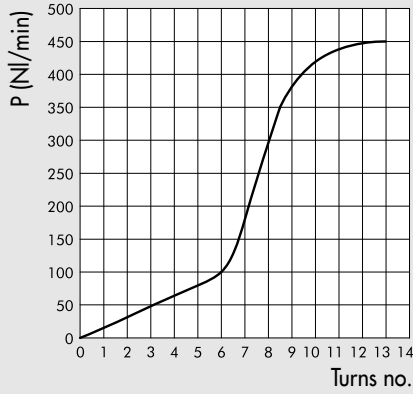

RFL L Ø 8

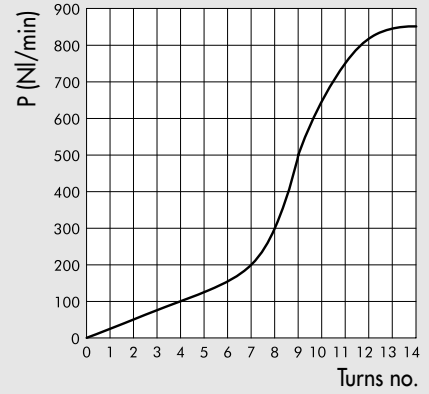

**RFL L PIPE-PIPE UNIDIRECTIONAL**

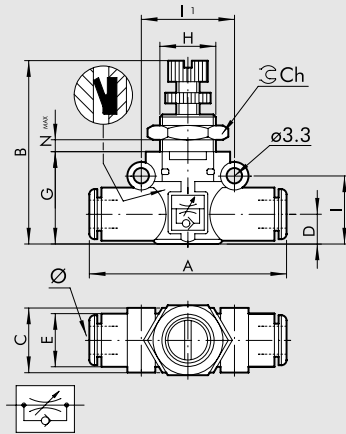

Code	Ref.	Ø	A	B	C	D	E	G	H	I	II	Ch	Nmax
9041301	RFL LU 4-4	4	42	33.5-36.5	10.7	5.6	10	17.5	M9x0.75	12.8	16	11	4
9041316	RFL LU 6-6	6	49.4	36-41	14.7	6.4	11.4	20	M12x0.75	14.6	20	15	4
9041324	RFL LU 8-8	8	57.3	44-49	18.7	9.1	13.8	26	M15x1	18.7	24	20	4.5

**RFL L THREAD-PIPE UNIDIRECTIONAL CYLINDER VERSION**

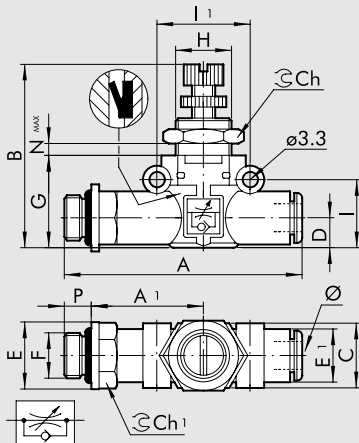

Code	Ref.	F	Ø	P	A	A1	B	C	D	E	E1	G	H	I	II	Ch	Ch1	Nmax
9041401	RFL LU M5-4	M5	4	4	47.7	22.7	33.5-36.5	10.7	5.6	9.9	10	17.5	M9x0.75	12.8	16	11	9	4
9041402	RFL LU 1/8-4	1/8	4	6	51.6	24.6	33.5-36.5	10.7	5.6	14	10	17.5	M9x0.75	12.8	16	11	12	4
9041408	RFL LU 1/8-6	1/8	6	6	58.5	27.8	36-41	14.7	6.4	14	11.4	20	M12x0.75	14.6	20	15	12	4
9041409	RFL LU 1/4-6	1/4	6	8	61.5	28.8	36-41	14.7	6.4	18	11.4	20	M12x0.75	14.6	20	15	14	4
9041410	RFL LU 1/8-8	1/8	8	6	66.2	31.8	44-49	18.7	9.1	15	13.8	26	M15x1	18.7	24	20	14	4.5
9041411	RFL LU 1/4-8	1/4	8	8	70.6	34.2	44-49	18.7	9.1	18	13.8	26	M15x1	18.7	24	20	14	4.5
9041412	RFL LU 3/8-8	3/8	8	9	72.2	34.8	44-49	18.7	9.1	22	13.8	26	M15x1	18.7	24	20	17	4.5

### RFL L PIPE-THREAD UNIDIRECTIONAL VALVE VERSION

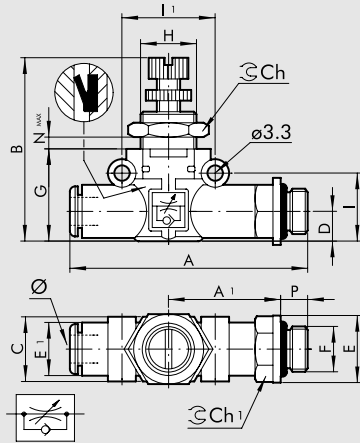

Code	Ref.	Ø	F	P	A	A1	B	C	D	E	E1	G	H	I	I1	Ch	Ch1	Nmax
9041501	RFL LU 4-M5	4	M5	4	47.7	22.7	33.5-36.5	10.7	5.6	9.9	10	17.5	M9x0.75	12.8	16	11	9	4
9041502	RFL LU 4-1/8	4	1/8	6	51.6	24.6	33.5-36.5	10.7	5.6	14	10	17.5	M9x0.75	12.8	16	11	12	4
9041508	RFL LU 6-1/8	6	1/8	6	58.5	27.8	36-41	14.7	6.4	14	11.4	20	M12x0.75	14.6	20	15	12	4
9041509	RFL LU 6-1/4	6	1/4	8	61.5	28.8	36-41	14.7	6.4	18	11.4	20	M12x0.75	14.6	20	15	14	4
9041510	RFL LU 8-1/8	8	1/8	6	66.2	31.8	44-49	18.7	9.1	15	13.8	26	M15x1	18.7	24	20	14	4.5
9041511	RFL LU 8-1/4	8	1/4	8	70.6	34.2	44-49	18.7	9.1	18	13.8	26	M15x1	18.7	24	20	14	4.5
9041512	RFL LU 8-3/8	8	3/8	9	72.2	34.8	44-49	18.7	9.1	22	13.8	26	M15x1	18.7	24	20	17	4.5

### RFL L PIPE-PIPE BIDIRECTIONAL

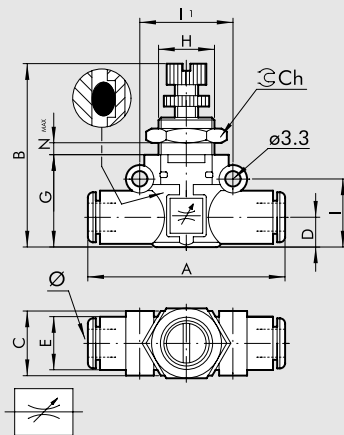

Code	Ref.	Ø	A	B	C	D	E	G	H	I	I1	Ch	Nmax
9041601	RFL LB 4-4	4	42	33.5-36.5	10.7	5.6	10	17.5	M9x0.75	12.8	16	11	4
9041616	RFL LB 6-6	6	49.4	36-41	14.7	6.4	11.4	20	M12x0.75	14.6	20	15	4
9041624	RFL LB 8-8	8	57.3	44-49	18.7	9.1	13.8	26	M15x1	18.7	24	20	4.5

### RFL L THREAD-PIPE BIDIRECTIONAL

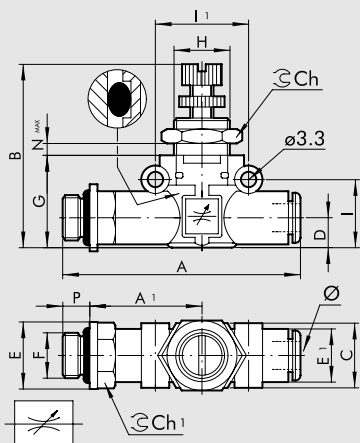

Code	Ref.	F	Ø	P	A	A1	B	C	D	E	E1	G	H	I	I1	Ch	Ch1	Nmax
9041701	RFL LB M5-4	M5	4	4	47.7	22.7	33.5-36.5	10.7	5.6	9.9	10	17.5	M9x0.75	12.8	16	11	9	4
9041702	RFL LB 1/8-4	1/8	4	6	51.6	24.6	33.5-36.5	10.7	5.6	14	10	17.5	M9x0.75	12.8	16	11	12	4
9041708	RFL LB 1/8-6	1/8	6	6	58.5	27.8	36-41	14.7	6.4	14	11.4	20	M12x0.75	14.6	20	15	12	4
9041709	RFL LB 1/4-6	1/4	6	8	61.5	28.8	36-41	14.7	6.4	18	11.4	20	M12x0.75	14.6	20	15	14	4
9041710	RFL LB 1/8-8	1/8	8	6	66.2	31.8	44-49	18.7	9.1	15	13.8	26	M15x1	18.7	24	20	14	4.5
9041711	RFL LB 1/4-8	1/4	8	8	70.6	34.2	44-49	18.7	9.1	18	13.8	26	M15x1	18.7	24	20	14	4.5
9041712	RFL LB 3/8-8	3/8	8	9	72.2	34.8	44-49	18.7	9.1	22	13.8	26	M15x1	18.7	24	20	17	4.5