

# AMERICAN AUDIO®

## ELMC-1

Professional Digital Producer

FEATURING



# User Guide and Reference Manual

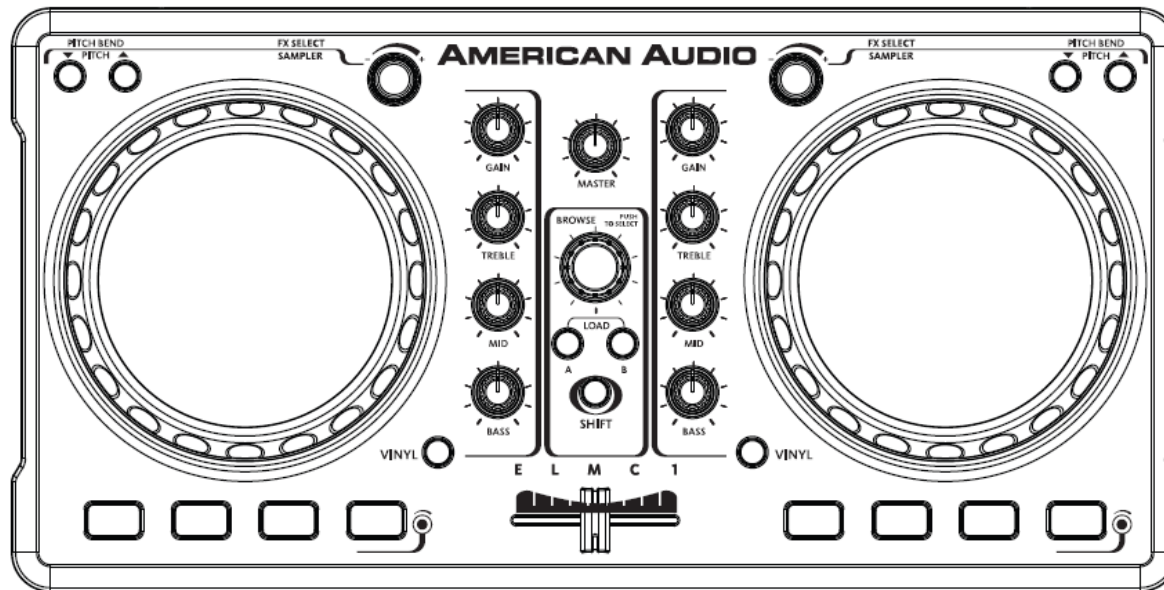

***Please Note:** All specifications and improvements to and in the design of this unit and this manual are subject to change at any time without any prior written or published noticed.*

**AMERICAN AUDIO®**  
6122 S. Eastern Ave  
Los Angeles Ca. 90040  
[www.americanaudio.eu](http://www.americanaudio.eu)

# 1. TABLE OF CONTENTS

1. Table of Contents.....	4
2. Electrical Safety Precautions .....	6
3. Important Safety Precautions.....	8
4. Further Safety Instructions .....	12
5. Unpacking .....	14
6. Introduction .....	15
6.1 Customer Support .....	15
7. Set-Up Precautions .....	16
7.1 Operating Determinations .....	16
8. Main Features.....	17
9. Minimum System Requirements* .....	18
9.1 PC Requirements.....	18
9.2 Mac Requirements.....	18
10. Set-Up.....	19
10.1 Checking the Contents .....	19

10.2	Installing the Units .....	19
10.3	Connections .....	19
11.	General Functions and Controls.....	20
11.1	Player Controls (Top) .....	20
11.2	Rear Panel .....	24
12.	Computer Connection.....	25
13.	Cleaning.....	27
14.	ROHS – A Contribution to the Conservation of Environment.....	28
15.	WEEE – Waste of Electrical and Electronic Equipment .....	29
16.	Specifications .....	30
16.1	General.....	30



## 2. ELECTRICAL SAFETY PRECAUTIONS



The lightning flash with an arrow triangular symbol is intended to alert the user to the presence of non-insulated “dangerous voltage” within the product’s enclosure, and may be of sufficient magnitude to constitute a risk of electric shock.





The exclamation point triangular symbol is intended to alert the user to the presence of important operating and maintenance (servicing) instructions in the user manual accompanying the unit.

	<p style="text-align: center;"><b>CAUTION</b></p> <p style="text-align: center;">RISK OF ELECTRIC SHOCK! DO NOT OPEN!</p> <p style="text-align: center;">TO REDUCE THE RISK OF ELECTRIC SHOCK, DO NOT REMOVE THE COVER RACK. THERE ARE NO USER SERVICEABLE PARTS INSIDE. REFER SERVICE TO YOUR AUTHORIZED AMERICAN AUDIO® SERVICE DEALER.</p>	
 <p>Please carefully read and understand the instructions in this manual thoroughly before attempting to operate this unit. These instructions contain important safety information regarding the use and maintenance of this unit. Take special care to follow all warning symbols and labels both on the unit and printed in this manual. Also, Please keep this manual with the unit, for future reference.</p>		

**CAUTION:**



- Handle the power supply cord carefully. Do not damage or deform; it may cause electric shock or malfunction when used. Hold the plug attachment when removing from wall outlet. Do not pull on the cord.
- To avoid electric shock, do not open the top cover when the unit is plugged in. If problems occur with the unit, call your local American Audio® dealer.
- Do not place metal objects or spill liquid inside the unit. Electric shock or malfunction may occur.

	<p style="text-align: center;"><b>CAUTION:</b></p> <p style="text-align: center;">TO PREVENT ELECTRIC SHOCK DO NOT USE THIS (POLARIZED) PLUG WITH AN EXTENSION CORD, RECEPTACLE OR OTHER OUTLET UNLESS THE BLADES CAN BE CAREFULLY INSERTED TO PREVENT BLADE EXPOSURE!</p>	
---	--	---

**CAUTION:**

- USE OF CONTROLS OR ADJUSTMENTS OTHER THAN THOSE SPECIFIED HEREIN MAY RESULT IN HAZARDOUS RADIATION EXPOSURE.
- THE DEVICE SHOULD NOT BE ADJUSTED OR REPAIRED BY ANYONE EXCEPT PROPERLY QUALIFIED SERVICE PERSONNEL.

<p><b>NOTE:</b></p> <p>This unit may cause interference to radio and television reception.</p>	<p><b>NOTE:</b></p> <p>This device uses a semiconductor laser. It is recommended for use in a room at the following temperature: 41° - 95°F or 5°C - 35°C.</p>
--	--

	<p style="text-align: center;"><b>WARNING:</b></p> <p style="text-align: center;">TO PREVENT FIRE OR SHOCK HAZARD, DO NOT EXPOSE THIS DEVICE TO WATER OR MOISTURE!</p>	
---	--	---

### 3. IMPORTANT SAFETY PRECAUTIONS

**Read Instructions** – All the safety and operating instructions should be read before the product is operated.

**Retain Instructions** – The safety and operating instructions should be retained for future reference.

**Heed Warnings** – All warnings on the product and in the operating instructions should be adhered to.

**Follow Instructions** – All operating and use instructions should be followed.

**Cleaning** – The product should be cleaned only with a polishing cloth or a soft dry cloth. Never clean with furniture wax, benzine, insecticides or other volatile liquids since they may corrode the cabinet.

**Attachments** – Do not use attachments not recommended by the product manufacturer as they may cause hazards.

**Water and Moisture** – Do not use this product near water — for example, near a bathtub, wash bowl, kitchen sink, or laundry tub, in a wet basement or near a swimming pool and the like.

**Accessories** – Do not place this product on an unstable cart, stand, tripod, bracket, or table. The product may fall, causing serious injury to a child or adult and serious damage to the product. Use only with a cart, stand, tripod, bracket, or table recommended by the manufacturer, or sold with the product. Any mounting of the product should follow the manufacturer's instructions, and should use a mounting accessory recommended by the manufacturer.

**Power Sources** – This product should be operated only from the type of power source indicated on the marking label. If you are not sure of the type of power supply to your home, consult your product dealer or local power company.

**Cart** – A product and cart combination should be moved with care. Quick stops, excessive force, and uneven surfaces may cause the product and cart combination to overturn.





**Ventilation** – Slots and openings in the cabinet are provided for ventilation and to ensure reliable operation of the product and to protect it from overheating, and these openings must not be blocked or covered. The openings should never be blocked by placing the product on a bed, sofa, rug, or other similar surface. This product should not be placed in a built-in installation such as a bookcase or rack unless proper ventilation is provided or the manufacturer’s instructions have been adhered to.

**Location** – The appliance should be installed in a stable location.

**Nonuse Periods** – The power cord of the appliance should be unplugged from the outlet when left unused for a long period of time.

### Grounding or Polarization

- If this product is equipped with a polarized alternating current line plug (a plug having one blade wider than the other), it will fit into the outlet only one way. This is a safety feature. If you are unable to insert the plug fully into the outlet, try reversing the plug. If the plug should still fail to fit, contact your electrician to replace your obsolete outlet. Do not defeat the safety purpose of the polarized plug.
- If this product is equipped with a three-wire grounding type plug, a plug having a third (grounding) pin, it will only fit into a grounding type power outlet. This is a safety feature. If you are unable to insert the plug into the outlet, contact your electrician to replace your obsolete outlet. Do not defeat the safety purpose of the grounding type plug.

**Outdoor Antenna Grounding** – If an outside antenna or cable system is connected to the product, be sure the antenna or cable system is grounded so as to provide some protection against voltage surges and built-up static charges.

Article 810 of the National Electrical Code, ANSI/NFPA 70, provides information with regard to proper grounding of the mast and supporting structure, grounding of the lead-in wire to an antenna discharge unit, size of grounding conductors, location of antenna-discharge unit, connection to grounding electrodes, and requirements for the grounding electrode. See **Figure 1**.

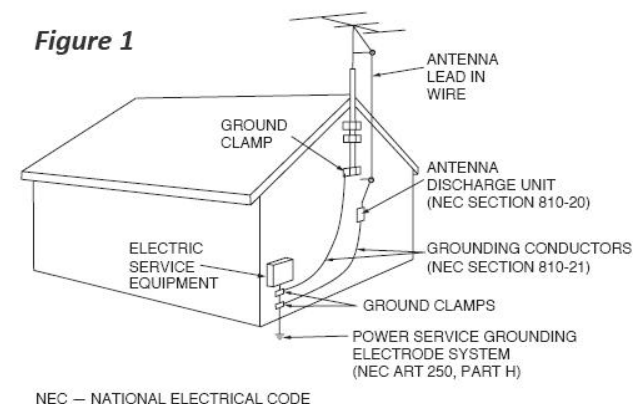

**Power Cord Protection** – Power-supply cords should be routed so that they are not likely to be walked on or pinched by items placed upon or against them, paying particular attention to cords at plugs, convenience receptacles, and the point where they exit from the product.

**Lightning** – For added protection for this product during a lightning storm, or when it is left unattended and unused for long periods of time, unplug it from the wall outlet and disconnect the antenna or cable system. This will prevent damage to the product due to lightning and power-line surges.

**Power Lines** – An outside antenna system should not be located in the vicinity of overhead power lines or other electric light or power circuits, or where it can fall into such power lines or circuits. When installing an outside antenna system, extreme care should be taken to keep from touching such power lines or circuits as contact with them might be fatal.

**Overloading** – Do not overload wall outlets, extension cords, or integral convenience receptacles as this can result in a risk of fire or electric shock.

**Object and Liquid Entry** – Never push objects of any kind into this product through openings as they may touch dangerous voltage points or short-out parts that could result in a fire or electric shock. Never spill liquid of any kind on the product.

**Servicing** – Do not attempt to service this product yourself as opening or removing covers may expose you to dangerous voltage or other hazards. Refer all servicing to qualified service personnel.

**Damage Requiring Service** – Unplug this product from the wall outlet and refer servicing to qualified service personnel under the following conditions:

- When the power supply cord or plug is damaged.
- If liquid has been spilled, or objects have fallen into the product.
- If the product has been exposed to rain or water.
- If the product has been dropped or damaged in any way.
- When the product exhibits a distinct change in performance - this indicates a need for service.

- If the product does not operate normally by following the operating instructions. Adjust only those controls that are covered by the operating instructions as an improper adjustment of other controls may result in damage and will often require extensive work by a qualified technician to restore the product to its normal operation.

**Replacement Parts** – When replacement parts are required, be sure the service technician has used replacement parts specified by the manufacturer or have the same characteristics as the original part. Unauthorized substitutions may result in fire, electric shock, or other hazards.

**Safety Check** – Upon completion of any service or repairs to this product, ask the service technician to perform safety checks to determine that the product is in proper operating condition.

**Wall or Ceiling Mounting** – The product should not be mounted to a wall or ceiling.

**Heat** – The product should be situated away from heat sources such as radiators, heat registers, stoves, or other products (including amplifiers) that produce heat.

## 4. FURTHER SAFETY INSTRUCTIONS

**Read Instructions** – All the safety and operating instructions should be read before the unit is operated. The safety and operating instructions should be saved for future reference.

**Heed Warnings** – All warnings on the unit and in the operating instructions should be adhered to.

**Water and Moisture** – The device should not be used near water - for example, near a bath tub, kitchen sink, laundry tub, in a wet basement or near a swimming pool, etc.

**Ventilation** – The device should be situated so that its location or position does not interfere with its proper ventilation. For example, the device should not be situated on a bed, sofa, rug, or similar surface that may block the ventilation openings; or, placed in a built-in installation, such as a bookcase or cabinet that may impede the flow of air through the ventilation openings.

**Heat** – The device should be situated away from heat sources such as radiators, heat registers, stoves, or other appliances (including amplifiers) that produce heat.

**Power Sources** – The device should be connected to a power supply only of the type described in the operating instructions or as marked on the unit.

**Servicing** – The user should not attempt to service the device beyond that described in the operating instructions. All other servicing should be referred to qualified service personnel. The device should be serviced by qualified service personnel when:

- The power-supply cord or the plug has been damaged.
- Objects have fallen, or liquid has been spilled into the unit.
- The unit has been exposed to rain or water.
- The unit does not appear to operate normally or exhibits a marked change in performance.

The serial and model number for this unit is located on the rear panel. Please write down the numbers here and retain for future reference.

**Model No.** \_\_\_\_\_

**Serial No.** \_\_\_\_\_

**Purchase Notes** \_\_\_\_\_

**Date of Purchase** \_\_\_\_\_

**Dealer Name** \_\_\_\_\_

**Dealer Address** \_\_\_\_\_

\_\_\_\_\_

\_\_\_\_\_

**Dealer Phone** \_\_\_\_\_

## 5. UNPACKING

Every ELMC-1 has been thoroughly tested and has been shipped in perfect operating condition.

Carefully check the shipping carton for damage that may have occurred during shipping. If the carton appears to be damaged, carefully inspect your system for any damage and be sure all equipment necessary to operate the system has arrived intact.

In the event damage has been found or parts are missing, please contact our toll free customer support number for further instructions.

Please do not return the system to your dealer without first contacting customer support.

## 6. INTRODUCTION

Congratulations and thank you for purchasing the American Audio® ELMC-1 Media Controller. This device is a representation of American Audio's® continuing commitment to produce the best and highest quality audio products possible at an affordable price. Please read and understand this manual completely before attempting to operate your new device. This booklet contains important information concerning the proper and safe operation of your new device.

### 6.1 CUSTOMER SUPPORT

American Audio® provides a toll free customer support line to provide set up help and to answer any questions, should you encounter problems during your initial set-up or operation. You may also visit us on the web at [www.AmericanAudio.us](http://www.AmericanAudio.us) for any comments or suggestions.

Service Hours are Monday through Friday 08:30 to 17:30 GMT+1.

- Voice: 0031 45 546 85 30
- Fax: 0031 45 546 85 99
- E-mail: [service@adjgroup.com](mailto:service@adjgroup.com)

For spare parts please look in our online part shop.

#### **Caution!**

*There are no user serviceable parts inside this device. Do not attempt any repairs by yourself. Doing so will void your manufactures warranty. In the unlikely event your device may require service, please contact American Audio® customer support.*

*Do not discard the packing carton in the trash. Please recycle whenever possible.*

## 7. SET-UP PRECAUTIONS

Please be sure to make any connections before plugging the device in to an electrical outlet.

All fader and volume controls should be set to zero or minimum position, before the device is switched on.

If the device has been exposed to drastic temperature fluctuation (e.g. after transportation), do not switch on the device immediately. The arising condensation of water might damage your device. Leave the device switched off until it has reached room temperature.

### 7.1 OPERATING DETERMINATIONS

When installing this device, please make sure that it is not exposed to extreme heat, moisture or dust!

- Do not operate the mixer in extremely hot (more than 40°C / 104°F) or extremely cold (less than 5°C / 40°F) surroundings.
- Keep the unit out of direct sunlight and away from heaters.
- Operate the device only after becoming familiar with its functions. Do not permit operation by persons not qualified for operating the unit. Most damages are the result of unprofessional operation!



## 8. MAIN FEATURES

- MIDI Control
- Seamless Loop (uninterrupted loop playback)
- Durable Touch Sensitive Jog Wheel
- Master Volume Control
- Crossfader
- 3 Band EQ

## 9. MINIMUM SYSTEM REQUIREMENTS\*

### 9.1 PC REQUIREMENTS

- Windows XP SP2 or Windows Vista (32-bit & 64-bit supported)
- PIV 1.2GHz Computer (SSE2 CPU), AMD 64 or greater
- 1024 x 768 SVGA Video
- 2 GB RAM (Vista)
- 40 MB free disk space (Recommended 2000 MB)
- DirectX 9.0

### 9.2 MAC REQUIREMENTS

- Mac OS X 10.5 PPC/Intel, 10.5.6 Intel, or 10.6 Intel
- 1.86 GHz
- 2 GB RAM

*\*System Requirements may differ due to manufacturer software*

## 10. SET-UP

### 10.1 CHECKING THE CONTENTS

Be sure your ELMC-1 was shipped with the following:

- ELMC-1 Controller
- Operating instructions (this booklet)
- USB Cable
- Virtual DJ Software
- Warranty card

*Caution: To avoid severe damage to the unit, be sure the power is off when making connections to the unit.*

### 10.2 INSTALLING THE UNITS

- Place your unit on a flat surface or secure case.
- Be sure the player is in a well-ventilated area where it will not be exposed to direct sunlight, high temperatures, or high humidity.
- Place the unit as far as possible from TVs and tuners, as the unit may cause undesirable interference.

### 10.3 CONNECTIONS

- Connect USB Cable

## 11. GENERAL FUNCTIONS AND CONTROLS

### 11.1 PLAYER CONTROLS (TOP)

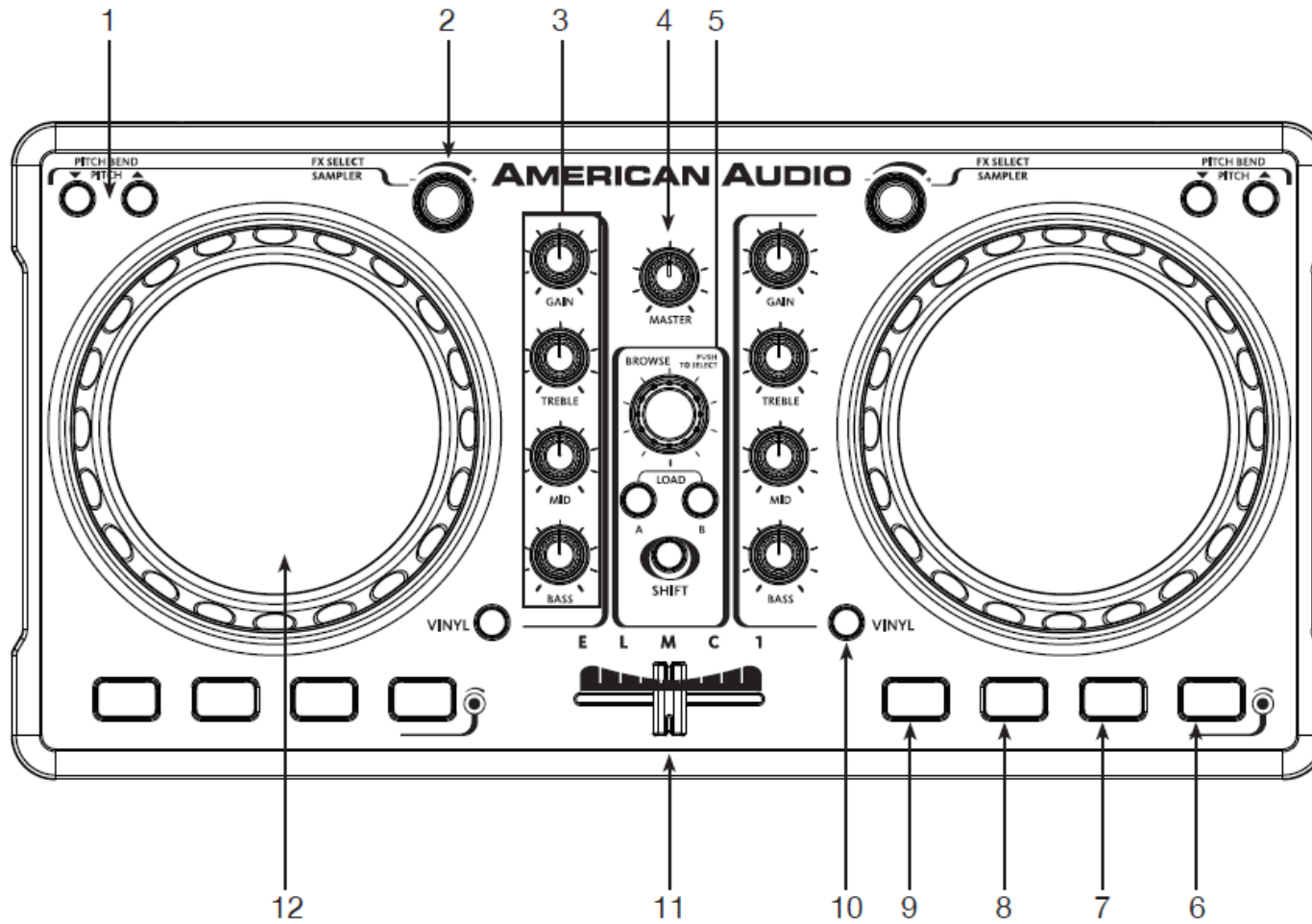

### (1) Pitch Bend Buttons –

- **(-) Pitch Bend Button** – The (-) pitch bend function creates a momentary “Slow Down” in the BPM’s (beats per minute) while it is playing. This will allow you to match the beats between two playing audio sources. Remember, this is a momentary function. When you remove your finger from the pitch button, the BPM will automatically return to the set pitch value. Holding down this button will give a maximum of -100% pitch.
- **(+) Pitch Bend Button** – The (+) pitch bend function creates a momentary “Bump” in the BPM (Beats per minute) while it is playing. This will allow you to match the beats between two playing audio sources. Remember, this is a momentary function. When you remove your finger from this button, the BPM will automatically return to the selected pitch. Holding down this button will give a maximum of +100% pitch.

### (2) FX Select/Sampler/Loop Adjustment –

- **FX Select** - This knob is used to set the desired FX. Once the desired effect appears in the effect window in Virtual DJ, press the knob to activate the effect. Once an effect is active, this knob will temporarily control the effect parameter until the effect is deactivated. Press the knob to deactivate the effect.
- **Sampler Select** - Holding *Shift* while turning this knob will set the sampler on in the sample window. Rotate the knob left or right once the desired effect is found. Start/Stop the sampler by pressing the knob. If a sample is active, the knob will control the volume temporarily while the sample is playing.
- **Loop Adjustment** - If a loop is active, this knob can control/adjust the loop size until the loop is exited.

### (3) Mixer Section –

- **Channel Gain Control** - This adjustment is used to adjust the audio source signal input gain for a channel. Never use the gain control to adjust a channel’s output volume. Setting the gain level properly will ensure a clean output signal. An improper gain level adjustment will send a distorted signal throughout the entire audio line which may damage speakers and amplifiers. To properly set a channels gain level control do as follows:

- Be sure the *Master Volume Control (4)* is set to level 4.
  - Set the *Gain Knob* to level 8.
  - Begin playback on an audio source connected to the channel you are adjusting.
  - Use the *Gain Control* to adjust an average output volume of +4 dB.
  - Repeat this step for all channels
- **Channel Treble Control** - This knob is used to adjust the treble levels of a channel allowing for a maximum treble gain of +6dB or maximum decrease of -100dB. Turning the knob in a counter-clockwise direction will decrease the amount of treble applied to a channel signal, turning the knob in a clockwise direction will increase the amount of treble applied to a channel signal.
  - **Channel Midrange Control** - This knob is used to adjust the midrange levels of a channel allowing for a maximum midrange gain of +6dB or maximum decrease of -100dB. Turning the knob in a counter-clockwise direction will decrease the amount of midrange applied to a channel signal, turning the knob in a clockwise direction will increase the amount of midrange applied to a channel signal.
  - **Channel Bass Control** - This knob is used to adjust the low frequency levels of a channel allowing for a maximum bass gain of +6dB or maximum signal decrease of -100dB. Turning the knob in a counter-clockwise direction will decrease the amount of bass applied to a channel signal, turning the knob in a clockwise direction will increase the amount of bass applied to a channel signal.

**(4) Master Volume Control** - This knob is used to control the master output level. To avoid distorted output try to maintain an average output signal level no greater than +4dB. To avoid speaker damage that may be caused by excessive volume, be sure this knob is always set to zero (completely down) before turning the unit on.

**(5) Navigation Buttons** - These buttons allow easy navigation of your music library on your software.

- **Browse Knob** - Turn this knob to scroll through and select your music tracks in the software. To enter a folder or return to the last folder in the software, press the knob.
- **Load Button** - Press this button to load the selected track to that deck. Pressing this button and the *Shift* button will cue the source to the headphones.
- **Shift Button** - Hold this to use secondary commands for certain buttons.

**(6) Loop** - This button will set a 4 beat loop and activate “loop divide and multiply” functions on the FX select knob.

**(7) Play/Pause Button** - Press this button to play/pause whatever music source is playing.

**(8) Cue** - Pressing the *Cue* button during playback immediately pauses playback and returns the track to the last set cue point. The red *Cue LED* will glow when the unit is in cue mode. The LED will also flash every time a new cue point is set. The *Cue* button can be held down to momentarily play the track. When you release the *Cue* button it instantly returns to the cue point. You can also tap the *Cue* button to create a „Bop Effect“.

**(9) Sync Button** - Use this button to set this deck to master and auto sync and the other deck's tempo to master.

**(10) Vinyl Button** - Pushing this button activates Scratch Mode.

**(11) Crossfader** - This fader is used to blend the output signals of channels A and B together. When the fader is in the full left position (channel A), the output signal of channel A will be controlled by the master volume level. The same fundamentals will apply for channel B. Sliding the fader from one position to another will vary the output signals of channels A and B respectively. When the crossfader is set in the center position, the output signals of both the channels A and channels B will be even.

**(12) Jog Wheel** - This wheel has three functions, described in the following sections.

**Attention:** Make sure that *NOTHING* is touching or resting on the jog wheels when you power on the ELMC-1.

- The wheel works as a pitch bend during playback. Turning the wheel clockwise can increase the pitch percentage up to 100%, and turning the wheel in the counter-clockwise direction can decrease the pitch percentage down to -100%. The pitch bend will be determined on how long you turn the jog wheel continuously.
- The jog wheel also controls the scratch effect, when the scratch effect is active.
- The jog wheel can also serve as frame search. To use frame search the track must be paused and the scratch effect must be disabled.

**Note:** The inside of the wheel is touch sensitive and the outside edge of the wheel is not. Example: You can scratch by touching the inside or center of the wheel, and pitch bend when you touch the outside edge of the wheel.

## 11.2 REAR PANEL

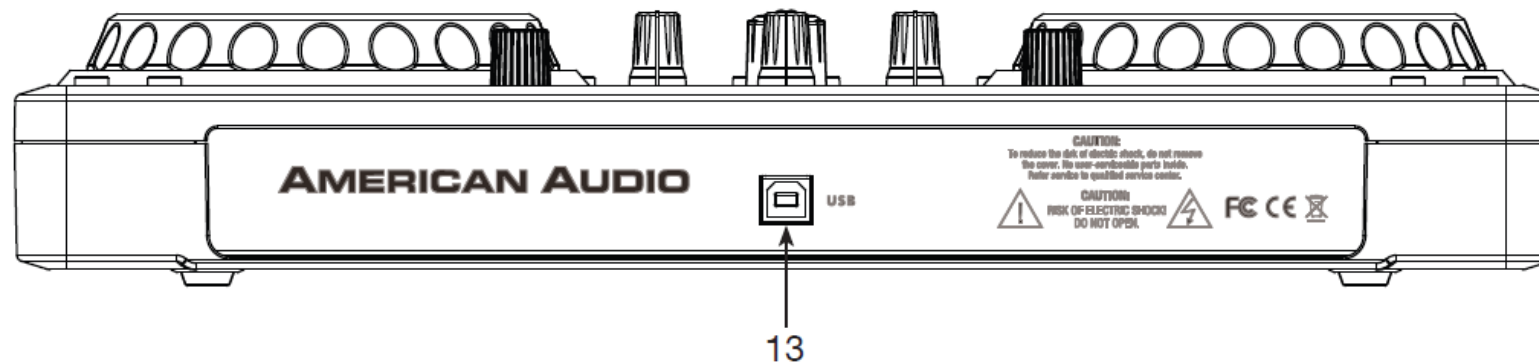

**(13) USB Port** - Connect to your PC for MIDI interface.



## 12. COMPUTER CONNECTION

Connect the ELMC-1 to your PC by using the USB port located on the rear of the ELMC-1 and your PC. Connect the supplied USB cable to the USB port on the rear of the ELMC-1, and the other end connects to the USB port on your computer.

**Note:** Before connecting your ELMC-1 to your computer or laptop, we highly recommend that you install the provided software. The Virtual DJ version included with this product is specifically tailored to work with the ELMC-1 with no setup required. The setup of other non-factory authorized drivers and software is far more complex and in some instances not as reliable.

### SIMPLE OUTPUT CONFIGURATION

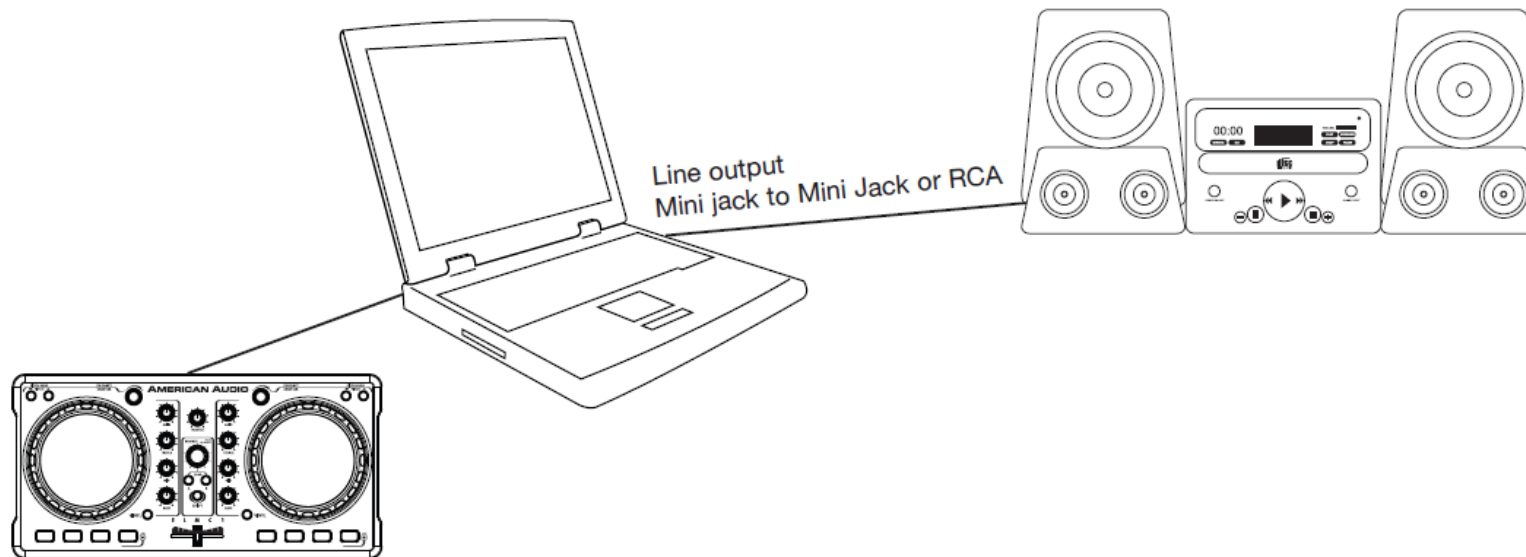

## MASTER AND HEADPHONE CONFIGURATION

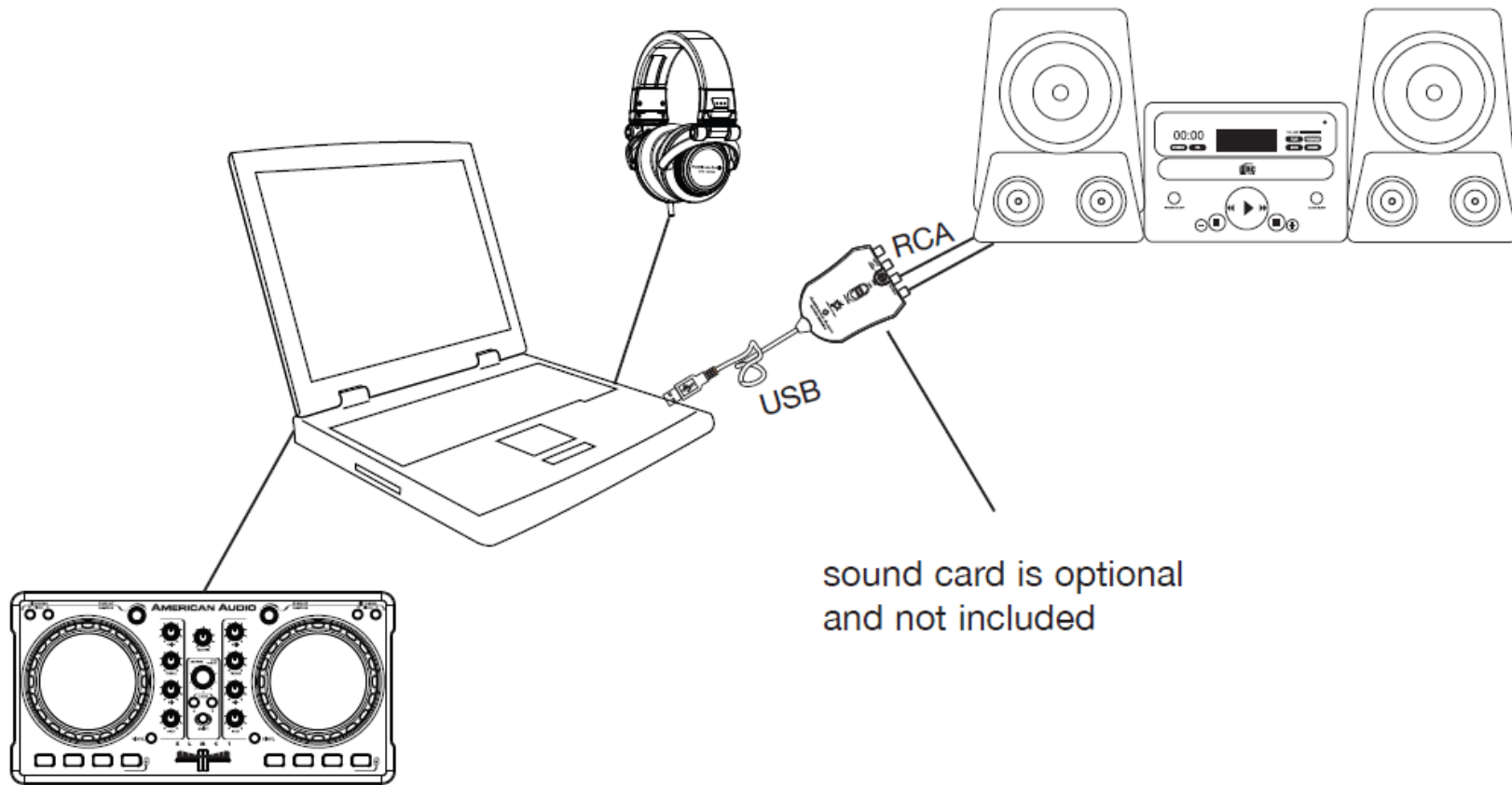

## 13. CLEANING

Due to fog residue, smoke, and dust, cleaning the mixer should be carried out periodically to residue build up.

- Use normal glass cleaner and a soft cloth to wipe down the outside casing.
- Use a cleaner specially designed for electronics to spray in and around the knobs and switch. This will reduce small particle built up that can effect the proper operation of the mixer.
- Cleaning should be carried out every 30-60 days to prevent heavy built up.
- Always be sure to dry all parts completely before plugging the mixer in.
- Cleaning frequency depends on the environment in which the mixer operates (i.e. smoke, fog residue, dust, dew).

## 14. ROHS – A CONTRIBUTION TO THE CONSERVATION OF ENVIRONMENT

The European Union has adopted a directive on the restriction/prohibition of the use of hazardous substances. This directive, referred to as ROHS, is a frequently discussed topic in the electronic industry.

It restricts, among other things, six materials: Lead (Pb), Mercury (Hg), Hexavalent Chromium (CR VI), Cadmium (Cd), Polybrominated Biphenyls as flame retardant (PBB), Polybrominated Diphenyl, also a flame retardant (PBDE). The directive applies to nearly all electronic and electrical devices whose mode of operation involves electric or electromagnetic fields – in short: each kind of electronics we have around us in our households or at work.

As manufacturers of products of the brands of AMERICAN AUDIO®, AMERICAN DJ®, ELATION Professional and ACCLAIM Lighting, we are obligated to comply with the ROHS directive. Therefore, as early as two years prior to the directive coming into force, we started our search for alternative environmentally friendly materials and manufacturing processes.

Well before the ROHS directive took effect, all of our products were manufactured meeting the standards of the European Union. With regular audits and material tests we can still assure that the components we use are always ROHS-compliant and that the manufacturing process, as far as the state of technology allows, is environmentally friendly.

The ROHS directive is an important step to the protection of our environment. We, as manufactures, feel obligated to make our contribution in this respect.

## 15. WEEE – WASTE OF ELECTRICAL AND ELECTRONIC EQUIPMENT

Every year thousands of tons of electronic components, which are harmful to the environment, end up at the waste disposals around the world. To ensure the best possible disposal or recovery of electronic components, the European Union has adopted the WEEE directive.

The WEEE-system (Waste of Electrical and Electronic Equipment) can be compared with the system of the “Green Spot”, which has been in use for several years. The manufactures have to make their contribution to the utilization of waste at the time they release the product. Money resources obtained by doing so will be applied to develop a common system of waste management. Thereby we can ensure professional and environmentally friendly scraping and recycling program.

As manufactures, we are part of the German system of EAR and we make our contribution towards it.

(Registration in Germany: DE41027552)

That means that products of AMERICAN DJ® and AMERICAN AUDIO® can be left in the collection points free of charge and they will be used in the recycling program. Products of ELATION Professional, which are used only by professionals, shall be handled by us. Please send Elation products directly to us at the end of their lifetime so that we can professionally dispose of them.

Like the above ROHS, the WEEE directive is an important contribution to the environment protection and we are glad to help to clean the environment with this disposal system.

We are happy to answer any of your inquiries and welcome your suggestions at: [info@americandj.eu](mailto:info@americandj.eu)

## 16. SPECIFICATIONS

### 16.1 GENERAL

Model:	American Audio® ELMC-1 - PC Media Controller
Dimensions:	399(L) x 300(W) x 40(H) mm 15.7"(L) x 12(W) x 1.5"(H)
Installation:	Place on flat surface or mount in flat case
Weight:	10.9 Lbs. / 4.93 kg
Power Supply:	USB-powered

**Note:** Specifications and improvements in the design of this unit and this manual are subject to change without any prior written notice. Check the American Audio Website for downloadable user software updates!



Follow us on:



[facebook.com/americanDJ](https://facebook.com/americanDJ)

[twitter.com/americanDJ](https://twitter.com/americanDJ)

[youtube.com/adjlighting](https://youtube.com/adjlighting)

**©American Audio® World Headquarters  
6122 S. Eastern Ave. Los Angeles, CA 90040 USA**

**Tel: 323-582-3322 Fax: 323-582-3311**

**Web: [www.AmericanAudio.us](http://www.AmericanAudio.us)**

**E-mail: [info@americanaudio.us](mailto:info@americanaudio.us)**

**American DJ Europe**

**Junostraat 2**

**6468 EW Kerkrade**

**Netherlands**

**[service@adjgroup.eu](mailto:service@adjgroup.eu)**

**[www.americandj.eu](http://www.americandj.eu)**

**Tel: +31 45 546 85 00**

**Fax: +31 45 546 85 99**