



## Features

- Compact, requires only 22.8 mm diameter panel space
- No backlash
- For use with precision potentiometers or other rotating devices up to 15 turns
- Designed for use with plastic shafts
- RoHS compliant\*

## H-516 Turns-Counting Dial

### Mechanical and Physical Characteristics

Number of Turns .....	0 to 15
Dial Divisions.....	50 per turn
Readability - Over 10 Turns .....	2 parts in 1000
Torque With Brake Engaged .....	5.0 N-cm (7.0 oz-in.) minimum
Markings.....	White on black background
Locking Brake .....	Yes
Weight.....	7 grams (0.25 oz.)
Screws .....	Slotted 4-40UN, 2 screws included, 120 ° apart
Screw Tightening Torque.....	16.94 N-cm (1.5 lbs.-in.) minimum

### Shaft and Bushing Requirements

Shaft Diameter Requirements.....	Refer to chart below
Shaft Extension Beyond Panel .....	17.5 mm (0.6890 in.) minimum 22.5 mm (0.8858 in.) maximum
Bushing Extension Beyond Panel.....	10 mm (0.3937 in.) maximum

### H-516 MOUNTING INSTRUCTIONS

1. Drill 2.0 mm (.0787 in.) diameter anti-rotation pin hole on vertical centerline, 9.5 mm (.375 in.) below center of potentiometer mounting hole.
2. Mount potentiometer in panel with nut and lockwasher supplied with the potentiometer.
3. Turn potentiometer shaft counterclockwise to obtain minimum resistance or voltage ratio. This is not necessarily identical with mechanical stop.
4. Loosen set screws in knob of dial. Set dial to "0.0" reading.
5. While holding outer ring of dial, position unit lightly against panel. Tighten knob set screws to potentiometer shaft.

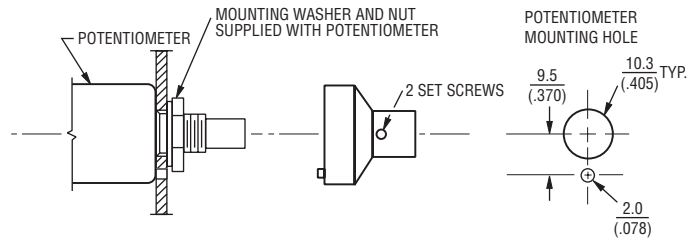

### Dimensional Drawings

TOLERANCES: EXCEPT WHERE NOTED  
 DECIMALS: .XX ± .01, .XXX ± .005  
 FRACTIONS: ±1/64  
 DIMENSIONS: MM (IN.)

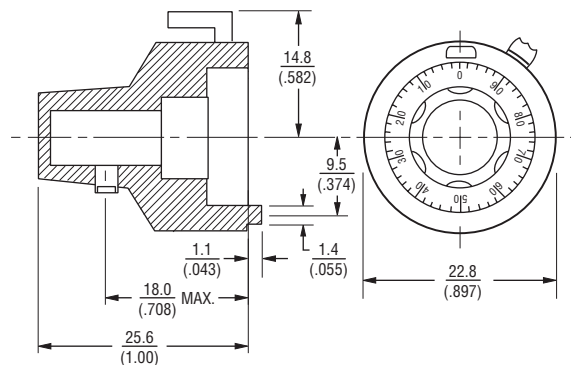

### How To Order

Part Number	Accepts Shaft Diameter	Finish
H-516-3A	3.17 mm (.125)	Satin Chrome
H-516-6A	6.35 mm (.250)	Satin Chrome
H-516-6M	6 mm (.236)	Satin Chrome

**BOURNS®**

**Asia-Pacific:**  
 Tel: +886-2 2562-4117  
 Fax: +886-2 2562-4116

**Europe:**  
 Tel: +41-41 768 5555  
 Fax: +41-41 768 5510

**The Americas:**  
 Tel: +1-951 781-5500  
 Fax: +1-951 781-5700  
[www.bourns.com](http://www.bourns.com)

REV. 10/11

\*RoHS Directive 2002/95/EC Jan 27, 2003 including Annex.  
 Specifications are subject to change without notice.  
 Customers should verify actual device performance in their specific applications.