

ORIENTAL MOTOR GENERAL CATALOGUE

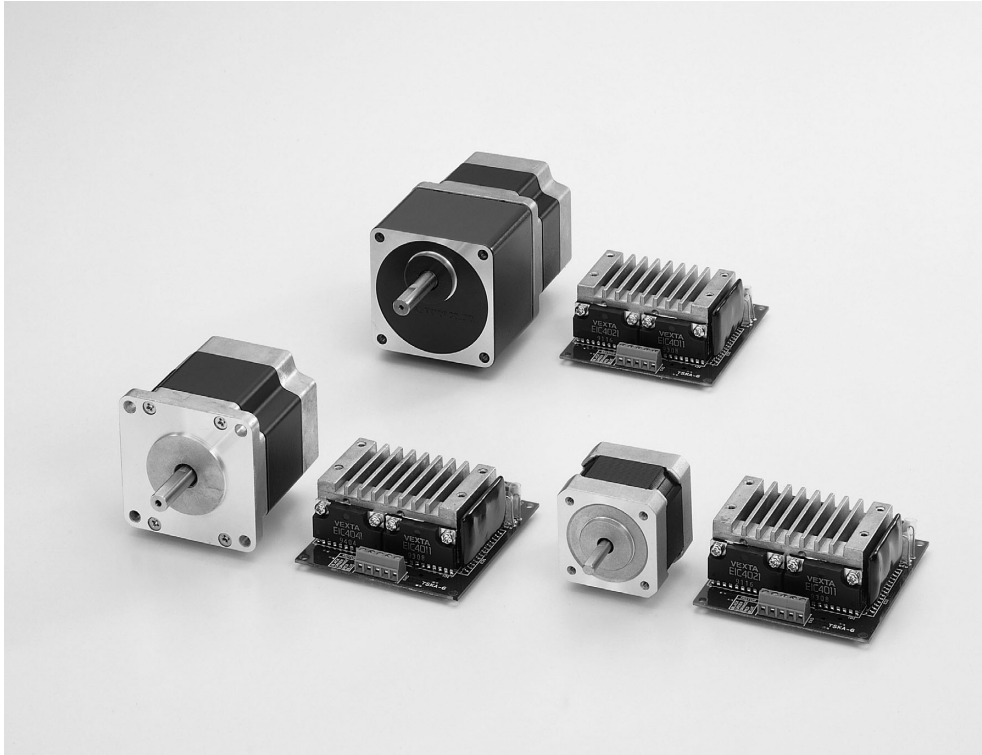

5-Phase CSK Series



5-Phase Stepping Motor and Driver Package

CSK Series

Features	B-118
List of Motor and Driver Combinations	B-120
Standard Type	B-121
TH Geared Type	B-125
Dimensions	B-129
Wiring Diagram	B-132
Description of Input/Output Signals	B-134
Switching and Setting Functions	B-136
Adjusting the Output Current	B-137

5-Phase Stepping Motor and Driver Package

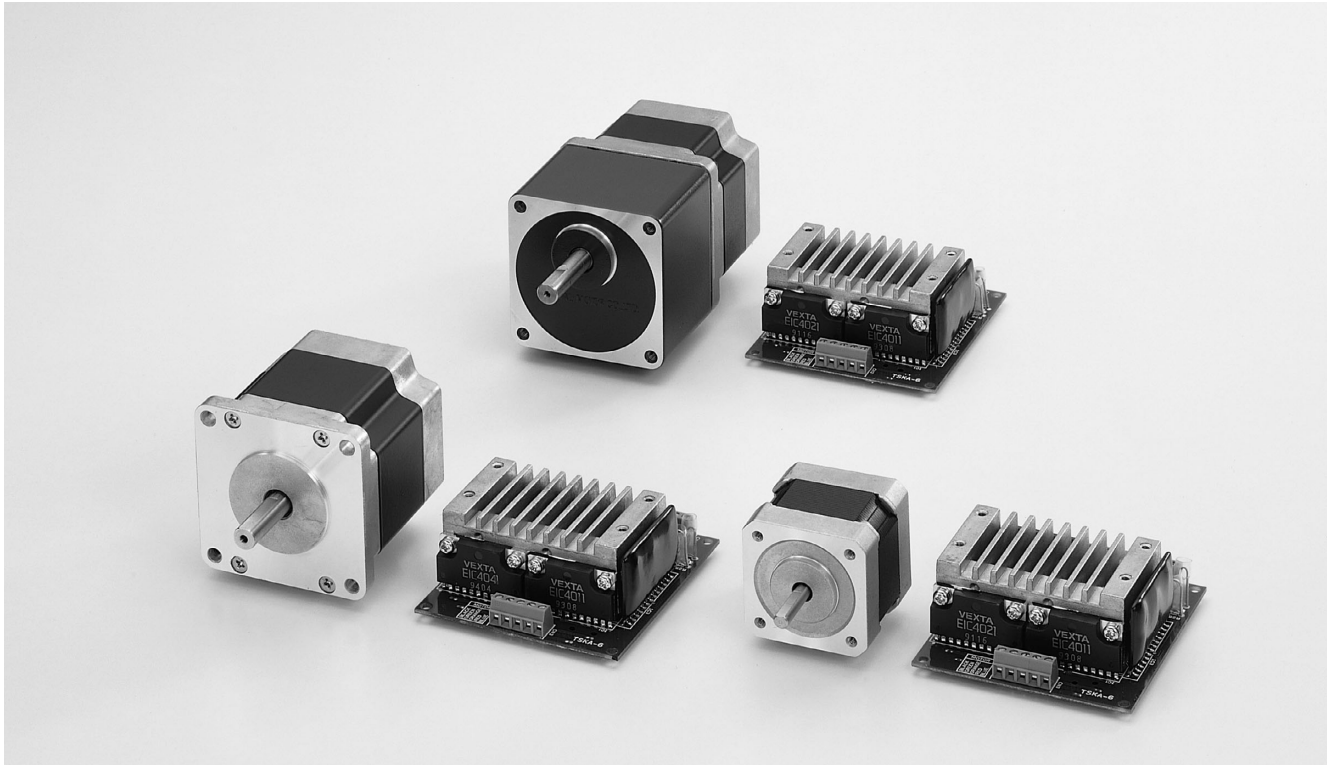
CSK Series**1. High torque**

The **PK** high torque motor was designed to produce high-torque in a compact frame size.

2. Low vibration

Because there is no noticeable resonance, smooth rotation is achieved. These packages keep vibration and noise levels low.

3. Compact package

Both the motor and driver are designed to be compact, making them perfect for reducing the size and weight of machines.

4. High resolution

The 5-phase stepping motors have 0.72° per step in full-step mode and 0.36° per step in half-step mode—2.5 times the resolution of a 2-phase stepping motor. This makes it possible for extremely accurate positioning.

5. TH geared type

The backlash-proof geared stepping motor features the compact body: What's more, these motors allow high permissible torque.

They are optimal for applications in which large torque is required in tight spaces.

※ **PK54**□ type motor dose not comply with CSA standards.
CSK59□ types are not recognized by UL and CSA.

CSK Series System Configuration

Combines a high torque 5-phase stepping motor with a compact driver for high-accuracy positioning control with open loop.

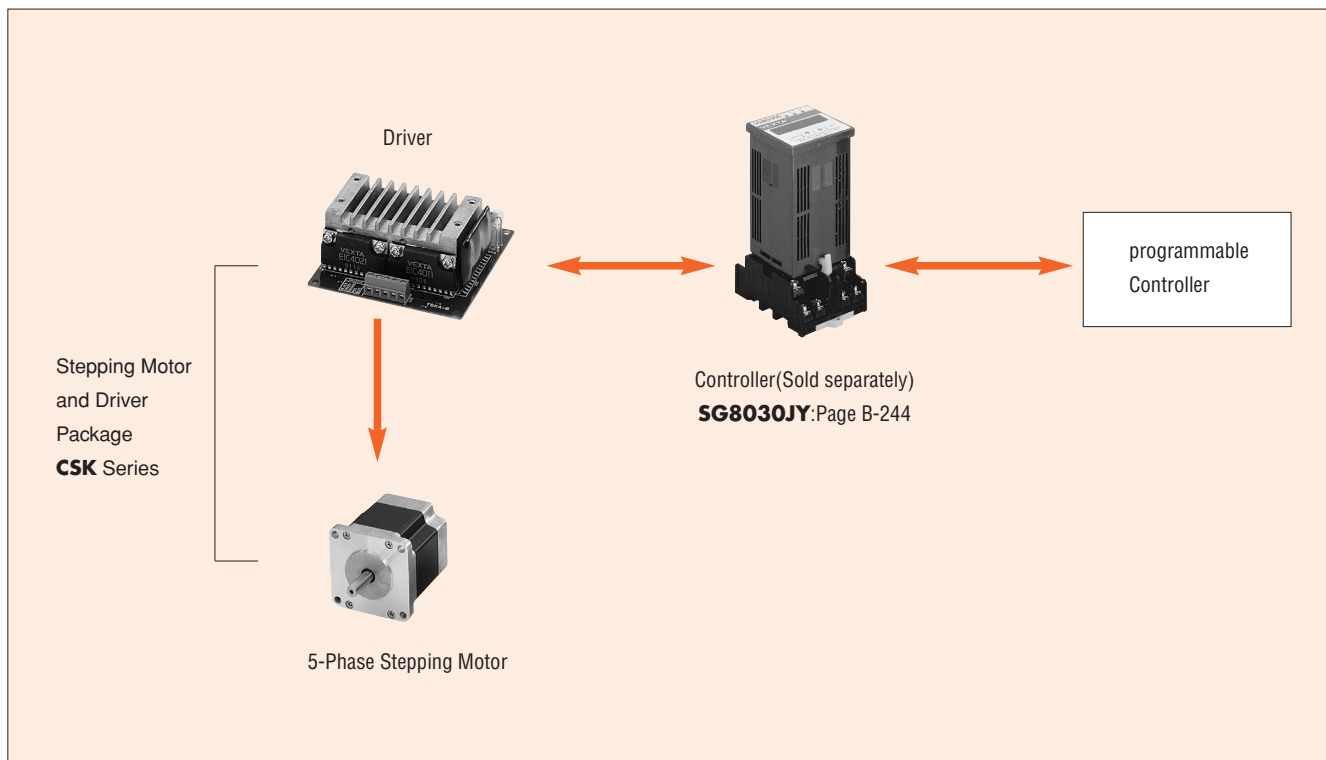

Accessories (Sold separately)

The diagram shows three accessories for the motor. On the left is a 'Motor Mounting Bracket'. In the center is a 'Clean Damper' attached to the motor's shaft. On the right is a 'Flexible coupling' attached to the motor's shaft.

- Motor Mounting Brackets: Page B-248
- Clean Dampers: Page B-251
- Flexible Couplings: Page B-252

Effective at suppressing motor vibration and improving performance.

Clamping Type

Note: Mounting brackets can not be fitted to **TH** geared motor types.

Note: Flexible Couplings can not be fitted to **TH** geared motor types.

CSK Series Standard Type Page B-121

Three sizes are available: **CSK54** □ with a frame size of 42mm square; **CSK56** □ 60mm square; and **CSK59** □ 85mm square.

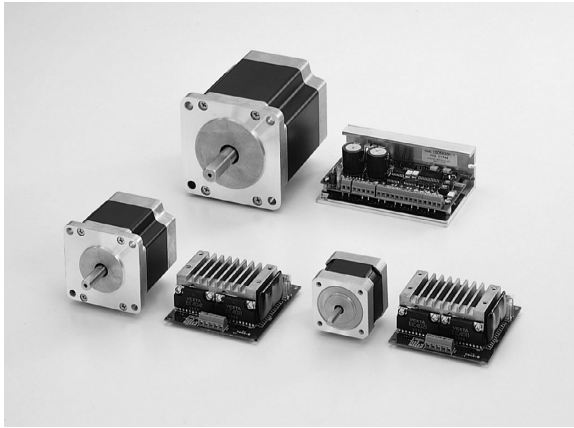

Standards /CE Marking

Products	Applicable Standards	Certification body	File. No.	CE Marking
Stepping Motor	UL1004, UL519			
	CSA C22.2 No.100 CSA C22.2 No.77	UL	E64199	
Driver	UL508C			EMC Directive
	CSA C22.2 No.14	UL	E171462	
	UL1950 CSA C22.2 No.950	UL	E208200	

PK54 □ type does not comply with CSA standards.
CSK59 □ types are not recognized by UL and CSA.

UL Approval Conditions

- The product is be used as a component within other equipment.
- Overvoltage Category : I
- Pollution Degree : 2
- Class III

List of Motor and Driver Combinations

Model numbers for motor and driver combinations are shown below.

Type	Package Model	Stepping Motor		Driver
		Model	Current A/phase	Model
Standard Type	CSK543-N □ TE CSK544-N □ TE CSK545-N □ TE	PK543N □ W PK544N □ W PK545N □ W	0.75	CSD5807N-T
	CSK564-N □ TE CSK566-N □ TE CSK569-N □ TE	PK564N □ WE PK566N □ WE PK569N □ WE	1.4	CSD5814N-T
	CSK596-N □ TE CSK599-N □ TE CSK5913-N □ TE	PK596-N □ E PK599-N □ E PK5913-N □ E	2.8	CSD5828N-T
TH Geared Type	CSK543AE-TG7.2 CSK543AE-TG10 CSK543AE-TG20 CSK543AE-TG30	PK543NAW-T7.2 PK543NAW-T10 PK543NAW-T20 PK543NAW-T30	0.75	CSD5807N-T
	CSK564AE-TG7.2 CSK564AE-TG10 CSK564AE-TG20 CSK564AE-TG30	PK564NAW-T7.2 PK564NAW-T10 PK564NAW-T20 PK564NAW-T30	1.4	CSD5814N-T

Enter **A**(single shaft)or **B**(double shaft) in the □ within the model numbers.

CSK Series TH Geared Type Page B-125

Four gear ratio are available: 1:7.2, 1:10, 1:20 and 1:30. The low ratios allows output shaft speed to be reduced without reducing the input pulse frequency, thus enabling more precise resolution and smoother rotation as low speed.

Refer to page B-18 for the details of **TH** gear.



Use Conditions

- Surroundings** The case of the driver of this product is not recognized as the enclosure. Protecting with the enclosure, please use.
- Power Supply** The driver power supply to be used should be a DC power supply where the primary and secondary sides are provided with reinforced insulation.
- EMC** The EMC value changes according to the wiring and layout. Therefore, the final EMC level must be checked with the motor/driver incorporated in the user's equipment.
- **EMI** Emission Tests: EN50081-2
Radiated Emission Test: EN55011
 - **EMS** Immunity Tests: EN61000-6-2
Radiation Field Immunity Tests: IEC61000-4-3
Electro Static Discharge Immunity Test: IEC61000-4-2 ※ 1
Fast Transient/Burst Immunity Test: IEC61000-4-4
Conductive Noise Immunity Test: IEC61000-4-6
- ※ 1 Except for **CSK54** □ type, **CSK56** □ type

Product Number Code

CSK 5 6 4 - N A T E

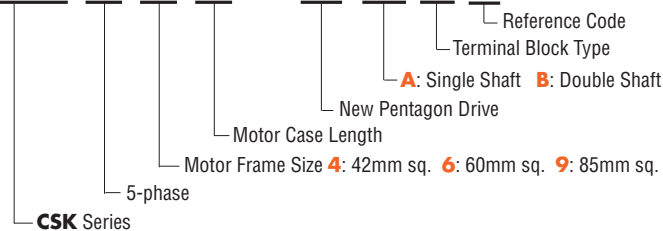

Specifications: Standard Type

Package Model	Single Shaft	CSK543-NATE	CSK544-NATE	CSK545-NATE	CSK564-NATE	CSK566-NATE	CSK569-NATE	
	Double Shaft	CSK543-NBTE	CSK544-NBTE	CSK545-NBTE	CSK564-NBTE	CSK566-NBTE	CSK569-NBTE	
Maximum Holding Torque	N · m	0.13	0.18	0.24	0.42	0.83	1.66	
Rotor Inertia	kg · m ²	35×10 ⁻⁷	54×10 ⁻⁷	68×10 ⁻⁷	175×10 ⁻⁷	280×10 ⁻⁷	560×10 ⁻⁷	
Rated Current	A/phase	0.75			1.4			
Basic Step Angle		0.72°						
Insulation Class		Class B (130°C) [Recognized as Class A (105°C) by UL and CSA standards]						
Power Source		DC24V±10% 1.3A maximum			DC24V±10% 2.1A maximum			
Output Current	A/phase	0.75			1.4			
Excitation Mode		<ul style="list-style-type: none"> ● Full Step : 0.72°/step (4 phase excitation) ● Half Step : 0.36°/step (4-5 phase excitation) 						
Input Signals	Input Signal Circuit	Photocoupler input, input resistance 220Ω, input current 20mA maximum Signal voltage Photocoupler ON : +4~+5V, Photocoupler OFF: 0~+0.5V						
	● Pulse Signal	Step Command Pulse Signal Pulse width: 5 μs minimum, Pulse rise/Pulse fall time: 2 μs maximum Motor moves when the photocoupler state changes from ON to OFF. Negative logic pulse input						
	● Rotation Direction Signal	Rotation Direction Signal Photocoupler ON : CW, Photocoupler OFF : CCW						
	● Step Angle Signal	Full Step (0.72°) at "Photocoupler OFF" Half Step (0.36°) at "Photocoupler ON"						
	● All Windings Off Signal	When in the "Photocoupler ON" state the current to the motor is cut off and the motor shaft can be rotated manually. When in the "Photocoupler OFF" state the current level set by the RUN switch is supplied to the motor.						
	● Automatic Current Cutback Release Signal	When in the "Photocoupler ON" state the "Automatic Current Cutback" function at motor standstill is disabled. When in the "Photocoupler OFF" state the "Automatic Current Cutback" function at motor standstill is activated. (Approximately 100ms after motor motion stops)						
Output Signals	Output Signal Circuit	Photocoupler, Open-Collector Output External use condition: 24V DC maximum, 10mA maximum						
	● Excitation Timing Signal	The signal is output every time the excitation sequence returns to the initial stage "0". (Photocoupler : ON) Full step: signal is output every 10 pulses, Half step: signal is output every 20 pulses						
Functions		Automatic current cutback						
Cooling Method (Driver)		Natural Ventilation						
Mass	Motor	kg	0.21	0.27	0.35	0.6	0.8	1.3
	Driver	kg	0.14					
Insulation Resistance	Motor	100M Ω or more under normal ambient temperature and humidity when the megger reading between the windings and the frame is DC500V.						
Dielectric Strength	Motor, Driver	Under normal ambient temperature and humidity, sufficient to withstand 1.0kV at 50 Hz (0.5kV for driver) applied between the windings and the frame for one minute following a period of continuous operation.						
Ambient temperature	Motor	-10°C ~ +50°C						
	Driver	0°C ~ +40°C						

- Maximum holding torque refers to the holding torque at motor standstill when the rated current is supplied to the motor (5 phase excitation). Use this value to compare motor torque performance. When using the motor with the included driver, the driver's "Automatic Current Cutback" function at motor standstill reduces maximum holding torque by approximately 50%.
- The power source input current value represents the maximum current. (The input current varies according to the pulse frequency.)

Package Model	Single Shaft	CSK596-NATE	CSK599-NATE	CSK5913-NATE
	Double Shaft	CSK596-NBTE	CSK599-NBTE	CSK5913-NBTE
Maximum Holding Torque	N · m	2.1	4.1	6.3
Rotor Inertia	kg · m ²	1400×10 ⁻⁷	2700×10 ⁻⁷	4000×10 ⁻⁷
Basic Rated Current	A/phase	2.8		
Step Angle		0.72°		
Insulation Class		Class B (130°C)		
Power Source		Motor Driving: DC24V±10% 4A maximum		
Output Current	A/phase	2.8		
Excitation Mode		<ul style="list-style-type: none"> ● Full Step : 0.72°/step (4 phase excitation) ● Half Step : 0.36°/step (4-5 phase excitation) 		
Input Signals	Input Signal Circuit	Photocoupler input, input resistance 220Ω, input current 20mA maximum Signal voltage Photocoupler ON : +4~+5V, Photocoupler OFF: 0~+0.5V		
	● Pulse Signal (CW Pulse Signal)	Step Command Pulse signal (CW Direction Command Pulse Signal at 2-pulse input mode) Pulse width: 5 μs minimum, Pulse rise/Pulse fall time: 2 μs maximum Motor moves when the photocoupler state changes from ON to OFF. Negative logic pulse input		
	● Rotation Direction Signal (CCW Pulse Signal)	Rotation Direction Signal Photocoupler ON : CW, Photocoupler OFF : CCW (CCW Direction Command Pulse Signal at 2-pulse input mode) Pulse width: 5 μs minimum, Pulse rise/Pulse fall time: 2 μs maximum Motor moves when the photocoupler state changes from ON to OFF.		
	● Step Angle Signal	Full Step (0.72°) at "Photocoupler OFF" Half Step (0.36°) at "Photocoupler ON"		
	● All Windings Off Signal	When in the "Photocoupler ON" state the current to the motor is cut off and the motor shaft can be rotated manually. When in the "Photocoupler OFF" state the current level set by the RUN switch is supplied to the motor.		
	● Automatic Current Cutback Release Signal	When in the "Photocoupler ON" state the "Automatic Current Cutback" function at motor standstill is disabled. When in the "Photocoupler OFF" state the "Automatic Current Cutback" function at motor standstill is activated. (Approximately 100ms after motor motion stops)		
Output Signals	Output Signal Circuit	Photocoupler, Open-Collector Output External use condition: 24V DC maximum, 10mA maximum		
	● Excitation Timing Signal	The signal is output every time the excitation sequence returns to the initial stage "0". (Photocoupler : ON) Full step: signal is output every 10 pulses, Half step: signal is output every 20 pulses		
	● Overheat Signal	Signal is output when the temperature of the driver radiation plate becomes 90°C. (Photocoupler ON, Automatic return.) The motor comes to a natural stop by "Automatic Current Off" function.		
Functions		Automatic current cutback, Automatic current off, Pulse signal mode switch		
Cooling Method (Driver)		Natural Ventilation		
Mass	Motor	kg	1.7	2.8
	Driver	kg	0.25	
Insulation Resistance	Motor	100M Ω or more under normal ambient temperature and humidity when the megger reading between the windings and the frame is DC500V.		
Dielectric Strength	Motor	Under normal ambient temperature and humidity, sufficient to withstand 1.0kV at 50 Hz applied between the windings and the frame for one minute following a period of continuous operation.		
Ambient temperature	Motor	-10°C ~ +50°C		
	Driver	0°C ~ +40°C		

- Maximum holding torque refers to the holding torque at motor standstill when the rated current is supplied to the motor (5 phase excitation). Use this value to compare motor torque performance. When using the motor with the included driver, the driver's "Automatic Current Cutback" function at motor standstill reduces maximum holding torque by approximately 50%.
- The power source input current value represents the maximum current. (The input current varies according to the pulse frequency.)

Speed-Torque Characteristics

fs: Maximum Starting Pulse Rate

Standard Type

CSK543-NBTE

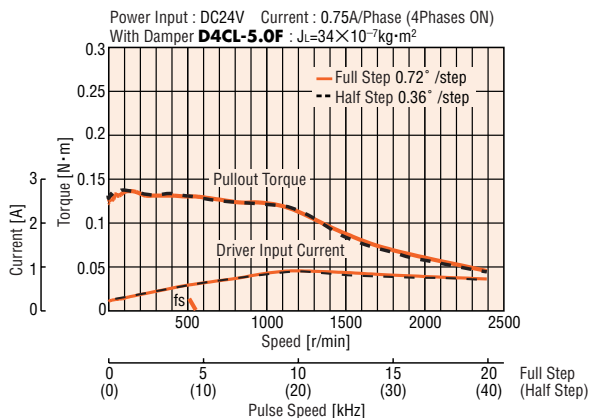

CSK564-NBTE

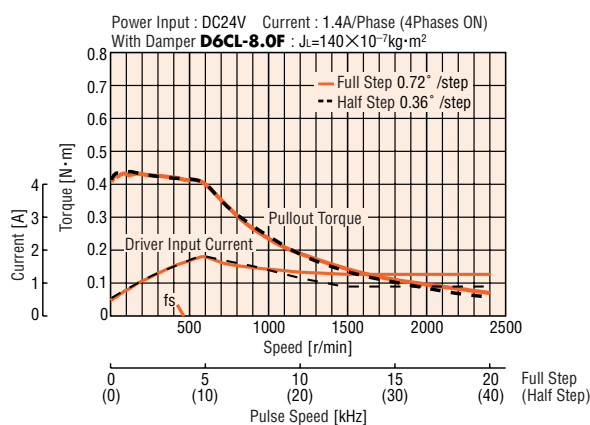

CSK544-NBTE

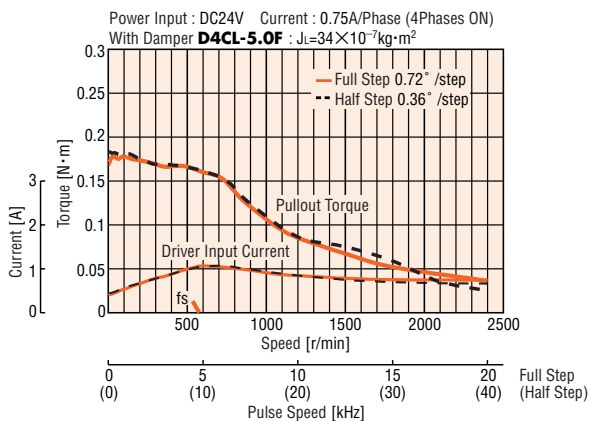

CSK566-NBTE

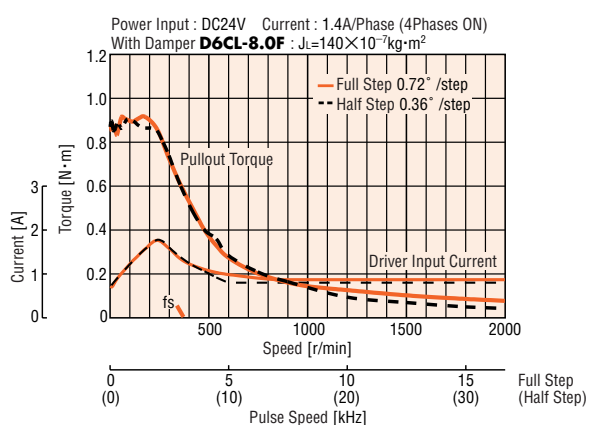

CSK545-NBTE

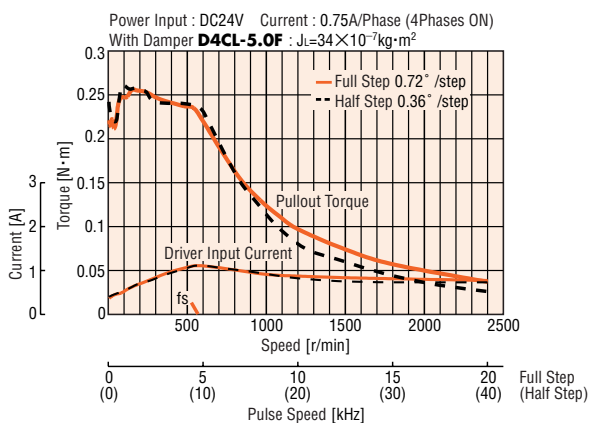

CSK569-NBTE

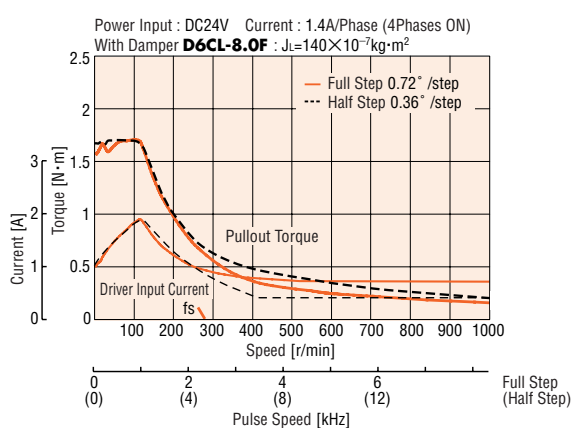

Notes:

1. Pay attention to heat dissipation from the motor and driver. The motor will produce a considerable amount of heat under certain conditions. Be sure to keep the temperature of the motor case under 100°C
2. When using the motor with the dedicated driver, the driver "Automatic Current Cutback" function at motor standstill reduces maximum holding torque by approximately 50%.

● Standard Type

CSK596-NBTE

Power Input : DC24V Current : 2.8A/Phase (4Phases ON)
 With Damper **D9CL-14F** : $J_L=870 \times 10^{-7} \text{kg} \cdot \text{m}^2$

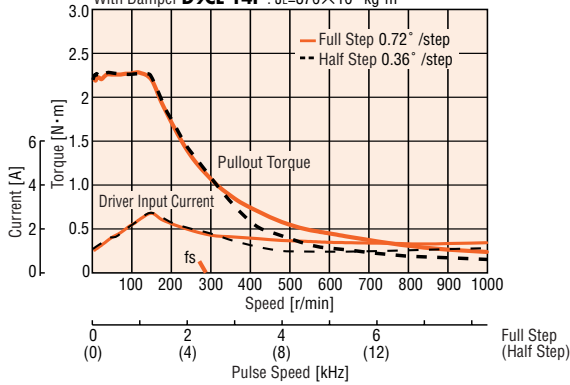

CSK599-NBTE

Power Input : DC24V Current : 2.8A/Phase (4Phases ON)
 With Damper **D9CL-14F** : $J_L=870 \times 10^{-7} \text{kg} \cdot \text{m}^2$

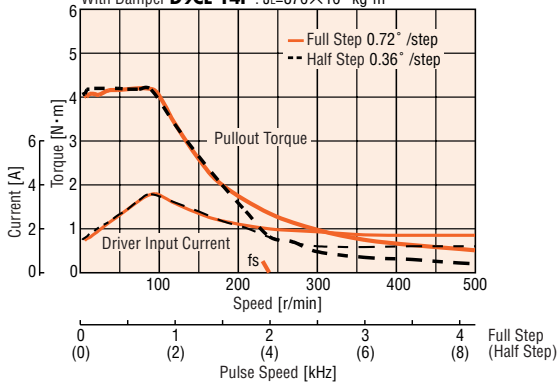

CSK5913-NBTE

Power Input : DC24V Current : 2.8A/Phase (4Phases ON)
 With Damper **D9CL-14F** : $J_L=870 \times 10^{-7} \text{kg} \cdot \text{m}^2$

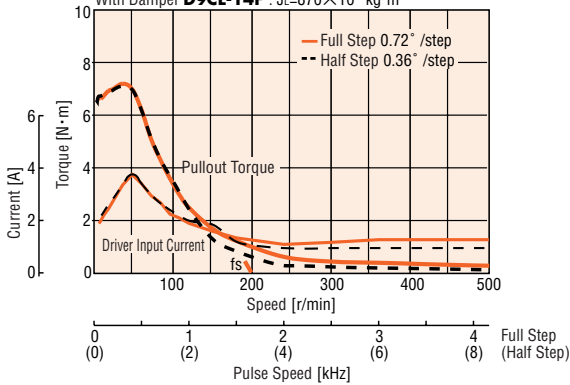

Notes:

1. Pay attention to heat dissipation from the motor and driver. The motor will produce a considerable amount of heat under certain conditions. Be sure to keep the temperature of the motor case under 100°C
2. When using the motor with the dedicated driver, the driver "Automatic Current Cutback" function at motor standstill reduces maximum holding torque by approximately 50%.

Product Number Code

CSK 5 6 4 A E - TG 10

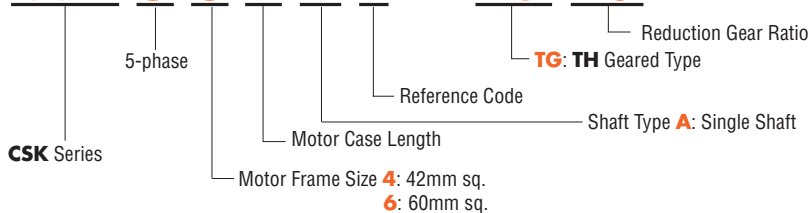

Specifications: TH Geared Type

Package Model	Single Shaft	CSK543AE-TG7.2	CSK543AE-TG10	CSK543AE-TG20	CSK543AE-TG30
Maximum Holding Torque	N · m	0.7	1.0	1.5	1.5
Rotor Inertia	kg · m ²	35 × 10 ⁻⁷			
Rated Current	A/phase	0.75			
Basic Step Angle		0.1°	0.072°	0.036°	0.024°
Reduction Gear Ratio		1:7.2	1:10	1:20	1:30
Permissible Torque	N · m	0.7	1.0	1.5	1.5
Permissible Thrust Load	N	15			
Permissible Overhung Load	N	20			
Backlash	Minute	25 (0.417°)	25 (0.417°)	15 (0.25°)	15 (0.25°)
Permissible Speed Range (Output Shaft Rotation Speed)	Full Step	0~15000Hz (0~250r/min)	0~15000Hz (0~180r/min)	0~15000Hz (0~90r/min)	0~15000Hz (0~60r/min)
	Half Step	0~30000Hz (0~250r/min)	0~30000Hz (0~180r/min)	0~30000Hz (0~90r/min)	0~30000Hz (0~60r/min)
Insulation Class		Class B (130°C) [Recognized as Class A (105°C) by UL and CSA standards]			
Power Source		DC24V ± 10% 1.3A Maximum			
Output Current	A/phase	0.75			
Excitation Mode	Full Step	0.1°/step	0.072°/step	0.036°/step	0.024°/step
	Half Step	0.05°/step	0.036°/step	0.018°/step	0.012°/step
Input Signals	Input Signal Circuit	Photocoupler input, input resistance 220Ω, input current 20mA maximum Signal voltage Photocoupler ON : +4~+5V, Photocoupler OFF: 0~+0.5V			
	● Pulse Signal	Step Command Pulse Signal Pulse width: 5 μs minimum, Pulse rise/Pulse fall time: 2 μs maximum Motor moves when the photocoupler state changes from ON to OFF. Negative logic pulse input			
	● Rotation Direction Signal	Rotation Direction Signal Photocoupler ON : CW, Photocoupler OFF : CCW			
	● Step Angle Signal	Full Step (0.72°) at "Photocoupler OFF" Half Step (0.36°) at "Photocoupler ON"			
	● All Windings Off Signal	When in the "Photocoupler ON" state the current to the motor is cut off and the motor shaft can be rotated manually. When in the "Photocoupler OFF" state the current level set by the RUN switch is supplied to the motor.			
Output Signals	● Automatic Current Cutback Release Signal	When in the "Photocoupler ON" state the "Automatic Current Cutback" function at motor standstill is disabled. When in the "Photocoupler OFF" state the "Automatic Current Cutback" function at motor standstill is activated. (Approximately 100ms after motor motion stops)			
	Output Signal Circuit	Photocoupler, Open-Collector Output External use condition: 24V DC maximum, 10mA maximum			
Output Signals	● Excitation Timing Signal	The signal is output every time the excitation sequence returns to the initial stage "0". (Photocoupler : ON) Full step: signal is output every 10 pulses, Half step: signal is output every 20 pulses			
	Functions	Automatic current cutback			
Driver Cooling Method (Driver)		Natural Ventilation			
Mass	Motor	kg	0.33		
	Driver	kg	0.14		
Insulation Resistance	Motor	100M Ω or more under normal ambient temperature and humidity when the megger reading between the windings and the frame is DC500V.			
Dielectric Strength	Motor, Driver	Under normal ambient temperature and humidity, sufficient to withstand 0.5kV 50 Hz applied between the windings and the frame for one minute following a period of continuous operation.			
Ambient temperature	Motor	-10° C ~ +50° C			
	Driver	0° C ~ +40° C			

- Maximum holding torque refers to the holding torque at motor standstill when the rated current is supplied to the motor (5-phase excitation), with consideration given to the permissible strength of the gear. Use this value to compare motor torque performance. When using the motor with the included driver, the driver's "Automatic Current Cutback" function at motor standstill reduces maximum holding torque by approximately 50%.
- The current indicated in power input is the driver's maximum input current when a load is applied to the motor. (The value varies according to the pulse speed.)
- Permissible torque is the maximum value of the mechanical strength of the gear unit. Use the product with a total torque (load and acceleration) less than the permissible torque.
- Permissible overhung load indicates the maximum value measured at 10mm from the tip of the gear output shaft.
- Direction of rotation of the motor and that of the gear output shaft are the same for the gear ratio 1:7.2 and 1:10. It is opposite for 1:20 or 1:30 ratio type.

Package Model	Single Shaft	CSK564AE-TG7.2	CSK564AE-TG10	CSK564AE-TG20	CSK564AE-TG30
Maximum Holding Torque	N · m	2.5	3.0	3.5	4.0
Rotor Inertia	kg · m ²	175×10 ⁻⁷			
Rated Current	A/phase	1.4			
Basic Step Angle		0.1°	0.072°	0.036°	0.024°
Reduction Gear Ratio		1:7.2	1:10	1:20	1:30
Permissible Torque	N · m	2.5	3.0	3.5	4.0
Permissible Thrust Load	N	40			
Permissible Overhung Load	N	100			
Backlash	Minute	15 (0.25°)	15 (0.25°)	10 (0.167°)	10 (0.167°)
Permissible Speed Range (Output Shaft Rotation Speed)	Full Step	0~15000Hz (0~250r/min)	0~15000Hz (0~180r/min)	0~15000Hz (0~90r/min)	0~15000Hz (0~60r/min)
	Half Step	0~30000Hz (0~250r/min)	0~30000Hz (0~180r/min)	0~30000Hz (0~90r/min)	0~30000Hz (0~60r/min)
Insulation Class		Class B (130°C) [Recognized as Class A (105°C) by UL and CSA standards]			
Power Source		DC24V±10% 2.1A Maximum			
Output Current	A/phase	1.4			
Excitation Mode	Full Step	0.1°/step	0.072°/step	0.036°/step	0.024°/step
	Half Step	0.05°/step	0.036°/step	0.018°/step	0.012°/step
Input Signals	Input Signal Circuit	Photocoupler input, input resistance 220Ω, input current 20mA maximum Signal voltage Photocoupler ON : +4~+5V, Photocoupler OFF: 0~+0.5V			
	● Pulse Signal	Step Command Pulse Signal Pulse width: 5 μs minimum, Pulse rise/Pulse fall time: 2 μs maximum Motor moves when the photocoupler state changes from ON to OFF. Negative logic pulse input			
	● Rotation Direction Signal	Rotation Direction Signal Photocoupler ON : CW, Photocoupler OFF : CCW			
	● Step Angle Signal	Full Step (0.72°) at "Photocoupler OFF" Half Step (0.36°) at "Photocoupler ON"			
	● All Windings Off Signal	When in the "Photocoupler ON" state the current to the motor is cut off and the motor shaft can be rotated manually. When in the "Photocoupler OFF" state the current level set by the RUN switch is supplied to the motor.			
Output Signals	● Automatic Current Cutback Release Signal	When in the "Photocoupler ON" state the "Automatic Current Cutback" function at motor standstill is disabled. When in the "Photocoupler OFF" state the "Automatic Current Cutback" function at motor standstill is activated. (Approximately 100ms after motor motion stops)			
	Output Signal Circuit	Photocoupler, Open-Collector Output External use condition: 24V DC maximum, 10mA maximum			
● Excitation Timing Signal	The signal is output every time the excitation sequence returns to the initial stage "0". (Photocoupler : ON) Full step: signal is output every 10 pulses, Half step: signal is output every 20 pulses				
	Functions	Automatic current cutback			
Driver Cooling Method (Driver)		Natural Ventilation			
Mass	Motor	kg	0.95		
	Driver	kg	0.14		
Insulation Resistance	Motor	100M Ω or more under normal ambient temperature and humidity when the megger reading between the windings and the frame is DC500V.			
Dielectric Strength	Motor, Driver	Under normal ambient temperature and humidity, sufficient to withstand 1.0kV 50 Hz (0.5kV for driver) applied between the windings and the frame for one minute following a period of continuous operation.			
Ambient temperature	Motor	-10° C ~ +50° C			
	Driver	0° C ~ +40° C			

- Maximum holding torque refers to the holding torque at motor standstill when the rated current is supplied to the motor (5-phase excitation), with consideration given to the permissible strength of the gear. Use this value to compare motor torque performance. When using the motor with the included driver, the driver's "Automatic Current Cutback" function at motor standstill reduces maximum holding torque by approximately 50%.
- The current indicated in power input is the driver's maximum input current when a load is applied to the motor. (The value varies according to the pulse speed.)
- Permissible torque is the maximum value of the mechanical strength of the gear unit. Use the product with a total torque (load and acceleration) less than the permissible torque.
- Permissible overhung load indicates the maximum value measured at 10mm from the tip of the gear output shaft.
- Direction of rotation of the motor and that of the gear output shaft are the same for the gear ratio 1:7.2 and 1:10. It is opposite for 1:20 or 1:30 ratio type.

Speed-Torque Characteristics

fs: Maximum Starting Pulse Rate

TH Geared Type

CSK543AE-TG7.2

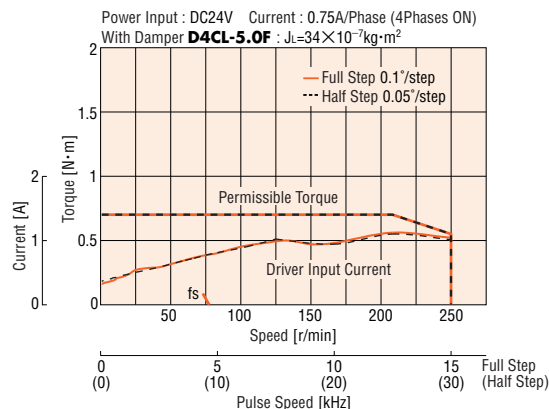

CSK564AE-TG7.2

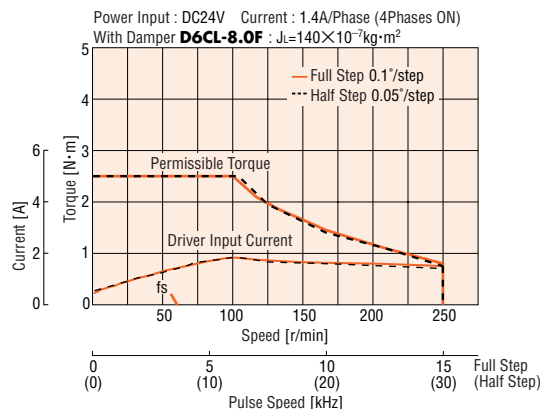

CSK543AE-TG10

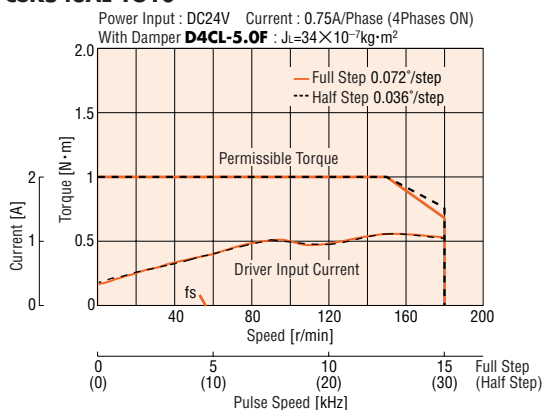

CSK564AE-TG10

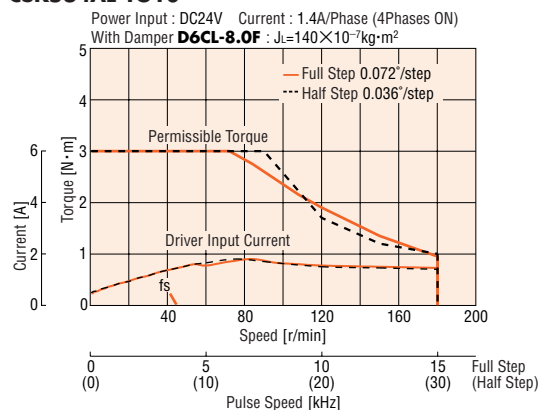

CSK543AE-TG20

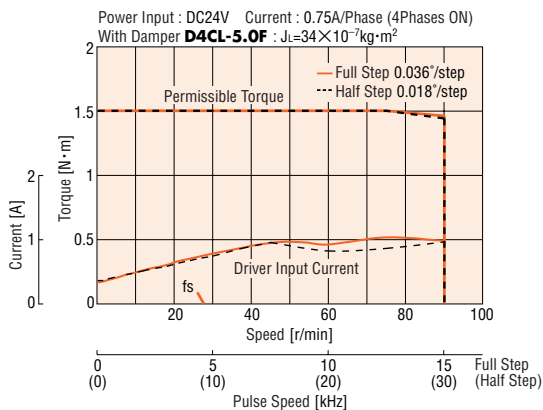

CSK564AE-TG20

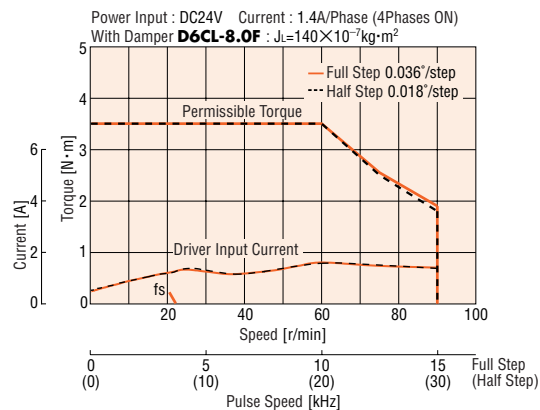

CSK543AE-TG30

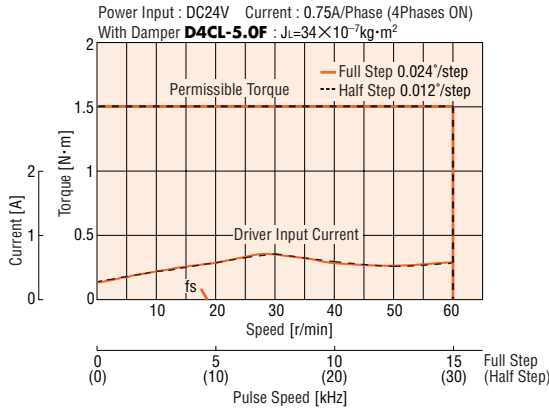

CSK564AE-TG30

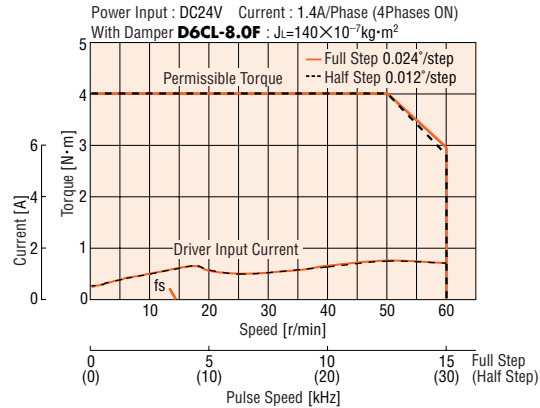

Notes:

1. Pay attention to heat dissipation from the motor and driver. The motor will produce a considerable amount of heat under certain conditions. Be sure to keep the temperature of the motor case under 100°C
2. When using the motor with the dedicated driver, the driver "Automatic Current Cutback" function at motor standstill reduces maximum holding torque by approximately 50%.

■ Precautions

When using the **CSK TH** geared type, please note the following:

1. Do not exceed the permissible torque:

Permissible torque represents the maximum value of the mechanical strength of the gear unit. Be sure to keep the total value of acceleration/deceleration torque and load (friction) torque at the shaft or stop of the motor under the permissible torque value. If torque exceeding the permissible torque is applied, the gear unit may fail.

2. Do not exceed the permissible speed range:

Do not exceed the maximum output speed of the gearhead indicated in the specifications on page B-125, 126. The speed affects the life the gearhead.

3. Consider backlash in bi-directional positioning:

Backlash is the free rotation angle (i.e., play) of the output shaft when the input section of the reduction gear is fixed. **CSK TH** geared type have been designed with a backlash of 15 arc minutes (gear ratio of 1:7.2 and 1:10) and 10 arc minutes (1:20 and 1:30). If, however, there is a problem with backlash in positioning in both directions, be sure to stop the motor in one direction. (In **CSK543AE-TG** □ models, backlash is 25 arc minutes and 15 arc minutes, respectively, for the above gear ratios.)

4. The direction of gear-shaft rotations differs according to gear ratios:

The direction of motor shaft rotation and gear shaft rotation according to the gear ratio applied:

Gear ratio - 1:7.2 and 1:10 - Same as motor shaft
 Gear ratio - 1:20 and 1:30 - Opposite of motor shaft

QSTEP

RK

CSK

PMC

NanoStep RPK

5-Phase Stepping Motors

CSK

2-Phase Stepping Motors

Controller

Accessories

Dimensions

Motor scale 1/4, unit=mm

CSK543-NATE (Single shaft)

Motor Model: PK543NAW Mass 0.21kg/Driver Model: CSD5807N-T

CSK543-NBTE (Double shaft)

Motor Model: PK543NBW Mass 0.21kg/Driver Model: CSD5807N-T

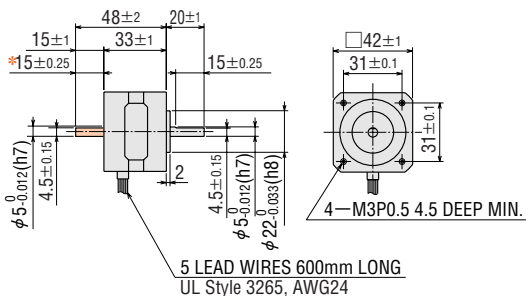

* 15±0.25 indicates the length of milling on motor shaft.

CSK544-NATE (Single shaft)

Motor Model: PK544NAW Mass 0.27kg/Driver Model: CSD5807N-T

CSK544-NBTE (Double shaft)

Motor Model: PK544NBW Mass 0.27kg/Driver Model: CSD5807N-T

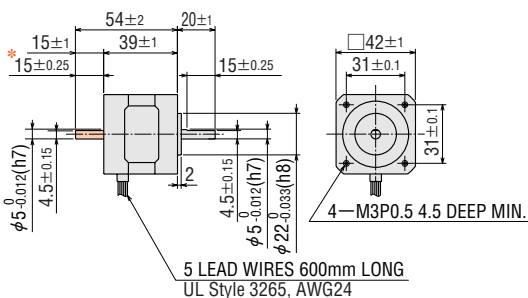

* 15±0.25 indicates the length of milling on motor shaft.

CSK545-NATE (Single shaft)

Motor Model: PK545NAW Mass 0.35kg/Driver Model: CSD5807N-T

CSK545-NBTE (Double shaft)

Motor Model: PK545NBW Mass 0.35kg/Driver Model: CSD5807N-T

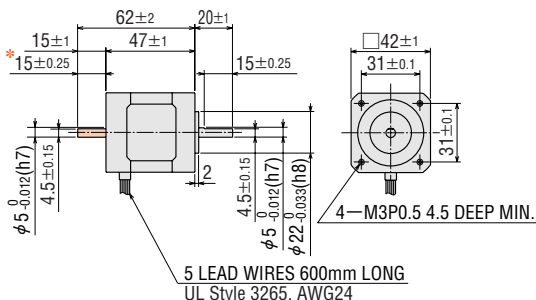

* 15±0.25 indicates the length of milling on motor shaft.

• These dimensions are for double shaft models. For single shaft, ignore the colored areas.

• Refer to page B-42 for information on motor installation.

CSK564-NATE (Single shaft)

Motor Model: PK564NAWE Mass 0.6kg/Driver Model: CSD5814N-T

CSK564-NBTE (Double shaft)

Motor Model: PK564NBWE Mass 0.6kg/Driver Model: CSD5814N-T

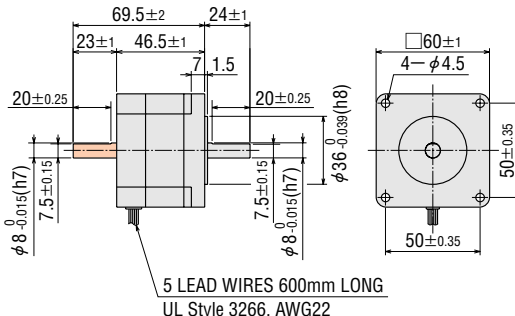

CSK566-NATE (Single shaft)

Motor Model: PK566NAWE Mass 0.8kg/Driver Model: CSD5814N-T

CSK566-NBTE (Double shaft)

Motor Model: PK566NBWE Mass 0.8kg/Driver Model: CSD5814N-T

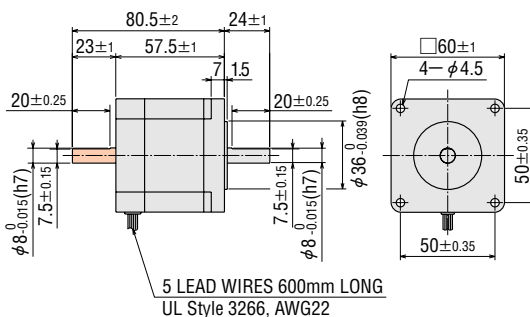

CSK569-NATE (Single shaft)

Motor Model: PK569NAWE Mass 1.3kg/Driver Model: CSD5814N-T

CSK569-NBTE (Double shaft)

Motor Model: PK569NBWE Mass 1.3kg/Driver Model: CSD5814N-T

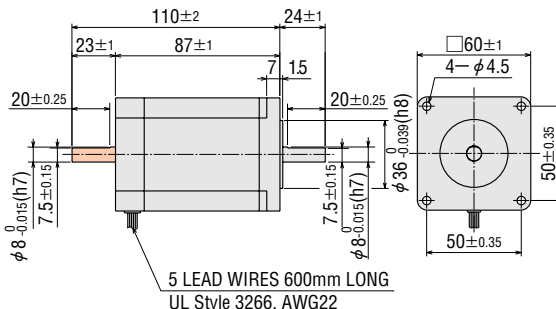

CSK596-NATE (Single shaft)
 Motor Model: PK596-NAE Mass 1.7kg/Driver Model: CSD5828N-T
CSK596-NBTE (Double shaft)
 Motor Model: PK596-NBE Mass 1.7kg/Driver Model: CSD5828N-T

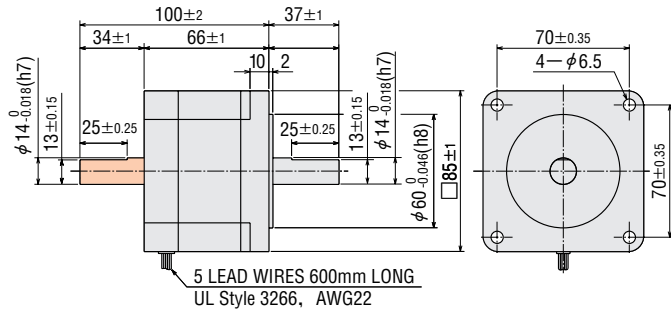

5 LEAD WIRES 600mm LONG
 UL Style 3266, AWG22

CSK543AE-TG □ (Single shaft)
 Motor Model: PK543NAW-T □ Mass 0.33kg/Driver Model: CSD5807N-T

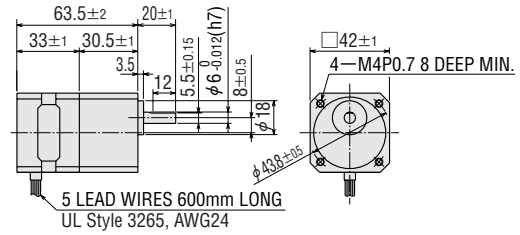

5 LEAD WIRES 600mm LONG
 UL Style 3265, AWG24

● Mounting Screws (included)
 M4 P0.7 10mm long: 4 pieces

CSK564AE-TG □ (Single shaft)
 Motor Model: PK564NAW-T □ Mass 0.95kg/Driver Model: CSD5814N-T

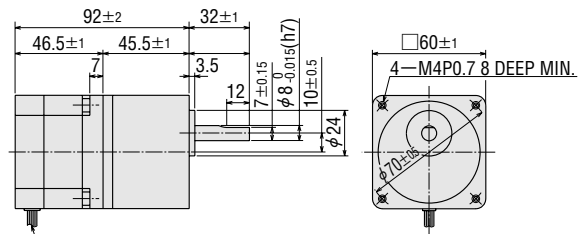

5 LEAD WIRES 600mm LONG
 UL Style 3266, AWG22

● Mounting Screws (included)
 M4 P0.7 18mm long: 4 pieces

CSK599-NATE (Single shaft)
 Motor Model: PK599-NAE Mass 2.8kg/Driver Model: CSD5828N-T
CSK599-NBTE (Double shaft)
 Motor Model: PK599-NBE Mass 2.8kg/Driver Model: CSD5828N-T

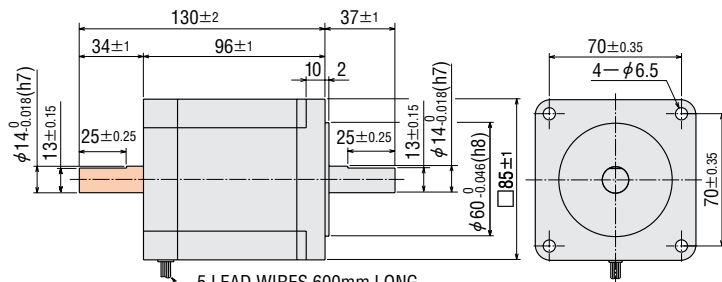

5 LEAD WIRES 600mm LONG
 UL Style 3266, AWG22

CSK5913-NATE (Single shaft)
 Motor Model: PK5913-NAE Mass 3.8kg/Driver Model: CSD5828N-T
CSK5913-NBTE (Double shaft)
 Motor Model: PK5913-NBE Mass 3.8kg/Driver Model: CSD5828N-T

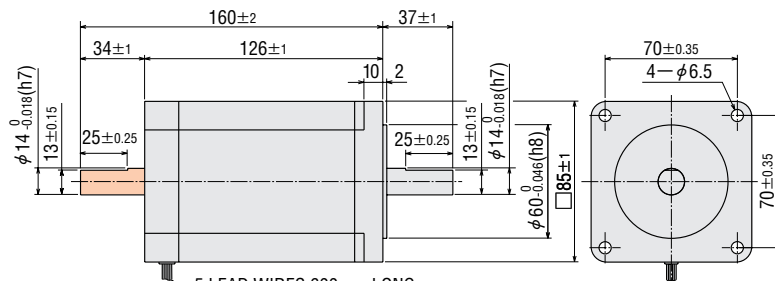

5 LEAD WIRES 600mm LONG
 UL Style 3266, AWG22

- These dimensions are for double shaft models. For single shaft, ignore the colored areas.
- Refer to page B-42 for information on motor installation.

● Driver scale 1/2, unit=mm

Driver: CSD5807N-T, CSD5814N-T Mass 0.14kg

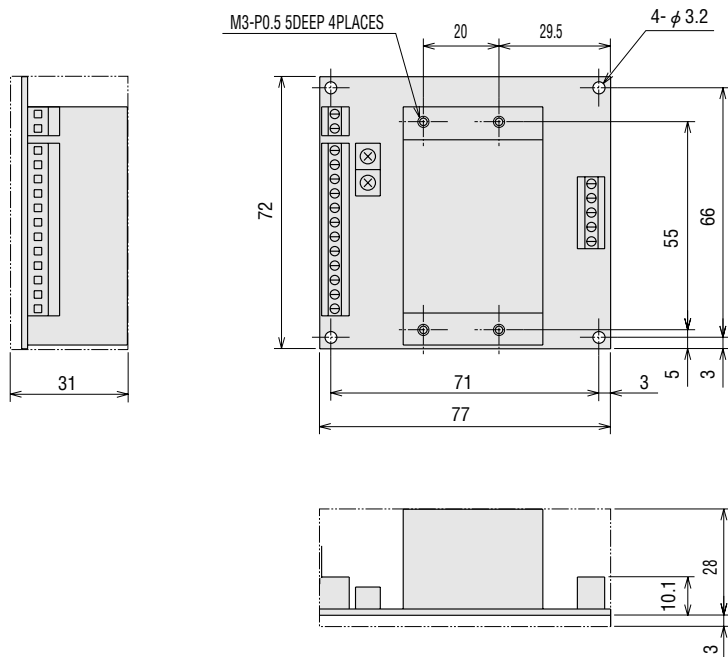

Driver: CSD5828N-T Mass 0.25kg

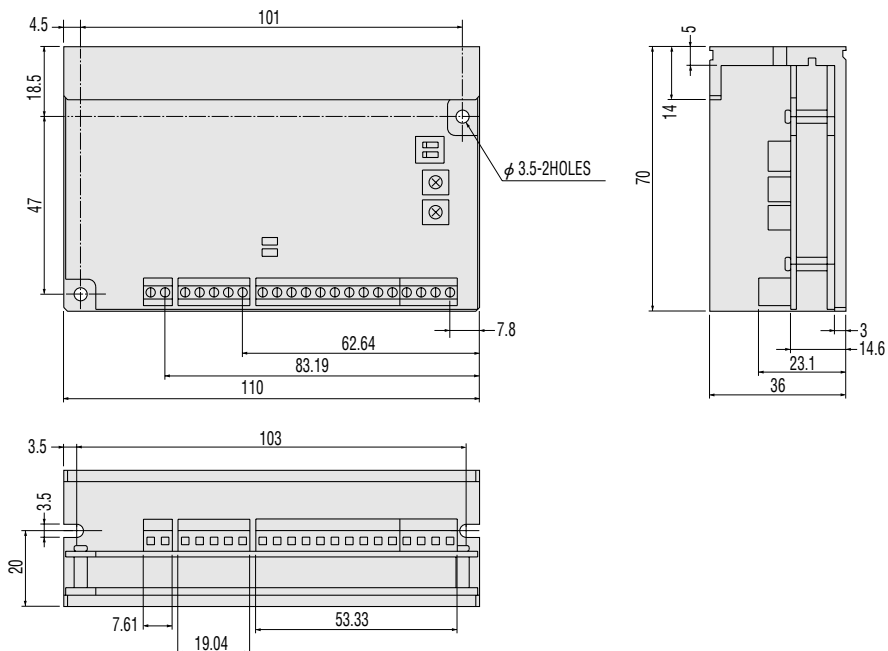

● Refer to page B-45 for information on driver installation.

Wiring Diagrams

- Standard Type CSK54 □, CSK56 □
- TH Geared Type CSK543AE-TG □, CSK564AE-TG □

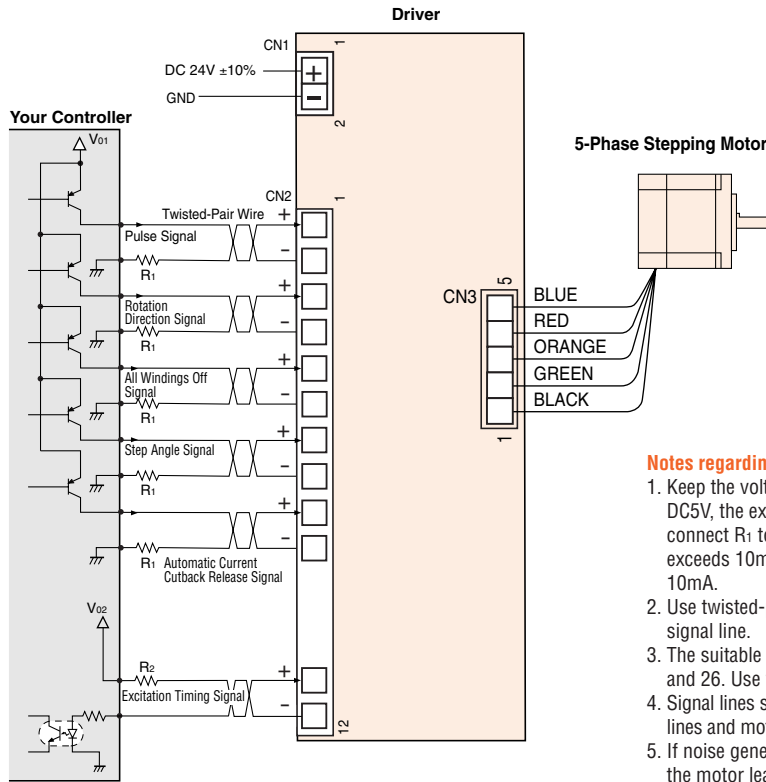

Notes regarding wiring

1. Keep the voltage V_{01} and V_{02} between DC5V and DC24V. When V_{01} is equal to DC5V, the external resistances R_1 is not necessary. When V_{01} is above DC5V, connect R_1 to keep the current below 20mA. When the output current exceeds 10mA, connect the external resistances R_2 to keep the current below 10mA.
2. Use twisted-pair wire of 0.2mm² or thicker and 2m or less in length for the signal line.
3. The suitable wire size for the CN1 and CN2 connectors is between AWG20 and 26. Use wires rated at AWG20 (0.5mm²) for the power line.
4. Signal lines should be kept at least 10cm away from power lines (power supply lines and motor lines). Do not bind the signal line and power line together.
5. If noise generated by the motor lead wire causes problem, try shielding of the motor lead wires with conductive tape or wire mesh.

Timing Chart

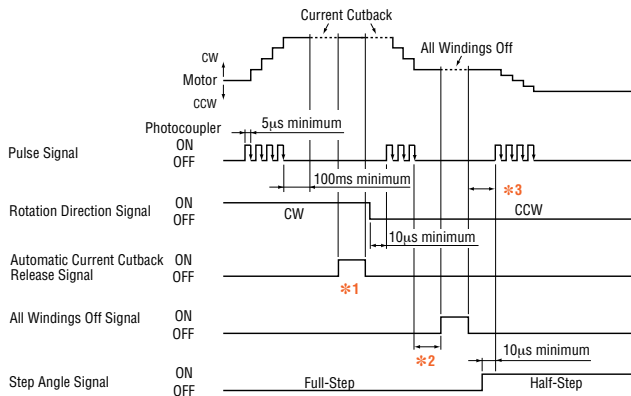

*1:

When the signal is in the "photocoupler ON" state, the "Automatic Current Cutback" function is deactivated. Always set it in the "photocoupler OFF" state when the pulse signal is stopped.

*2:

It is recommended to wait a period of time to allow the motor oscillations to end before inputting the "All Windings Off" signal. This time varies with the load inertia, the load torque and the starting pulse rate, etc. The signal input must be stopped before the motor stops.

*3:

Do not input pulse signals immediately after switching the "All Windings Off" signal into the "photocoupler OFF" state, as this will affect the motor's start-up characteristics. Ordinarily, the interval should be around 100ms.

■ Wiring Diagrams

● Standard Type CSK59 □ Type

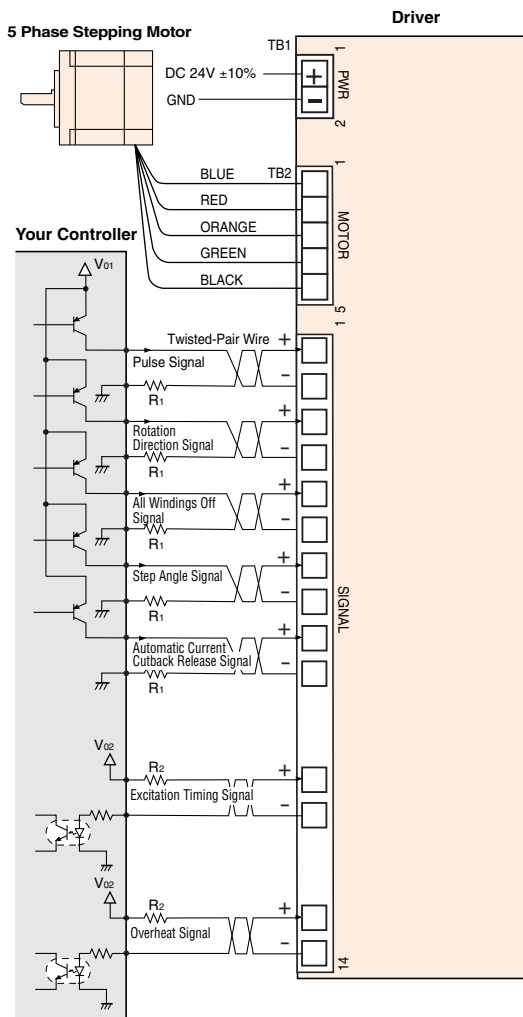

Notes regarding wiring

1. Keep the voltage V_{01} and V_{02} between DC5V and DC24V. When V_{01} is equal to DC5V, the external resistances R_1 is not necessary. When V_{01} is above DC5V, connect R_1 to keep the current below 20mA. When the output current exceeds 10mA, connect the external resistances R_2 to keep the current below 10mA.
2. Use twisted-pair wire of 0.2mm² or thicker and 2m or less in length for the signal line.
3. The suitable wire size for the TB1 and TB2 connectors is between AWG20 and 26. Use wires rated at AWG20 (0.5mm²) for the power line.
4. Signal lines should be kept at least 10cm away from power lines (power supply lines and motor lines). Do not bind the signal line and power line together.
5. If noise generated by the motor lead wire causes problem, try shielding of the motor lead wires with conductive tape or wire mesh.

■ Timing Chart

● 1-Pulse Input Mode

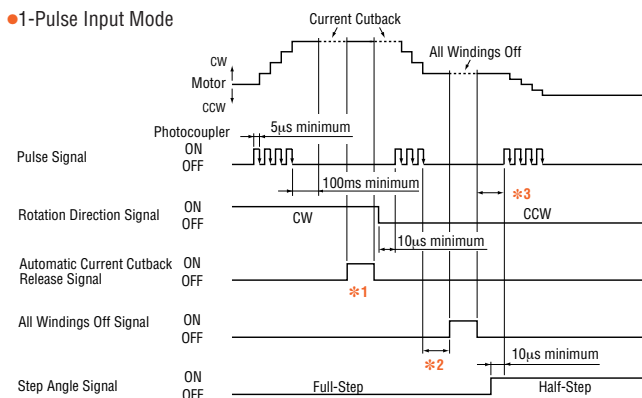

● 2-Pulse Input Mode

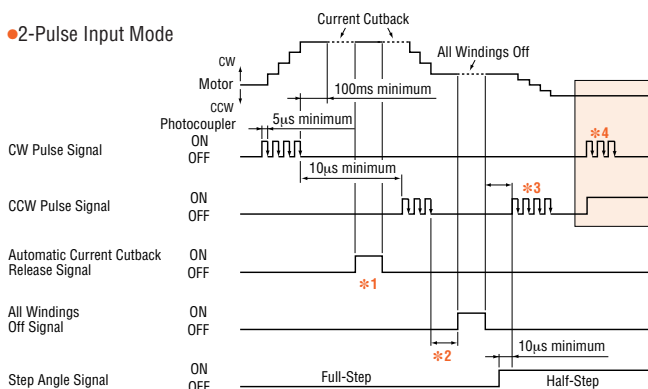

*1:

When the signal is in the "photocoupler ON" state, the "Automatic Current Cutback" function is deactivated. Always set it in the "photocoupler OFF" state when the pulse signal is stopped.

*2:

It is recommended to wait a period of time to allow the motor oscillations to end before inputting the "All Windings Off" signal. This time varies with the load inertia, the load torque and the starting pulse rate, etc. The signal input must be stopped before the motor stops.

*3:

Do not input pulse signals immediately after switching the "All Windings Off" signal into the "photocoupler OFF" state, as this will affect the motor's start-up characteristics. Ordinarily, the interval should be around 100ms.

*4:

The motor will not operate properly when inputting a pulse signal while either the CW or CCW pulse is in the "photocoupler ON" state.

■ Description of Input/Output Signals

1. Pulse (Pulse and Direction) Signal

■ Input Circuit and Sample Connection

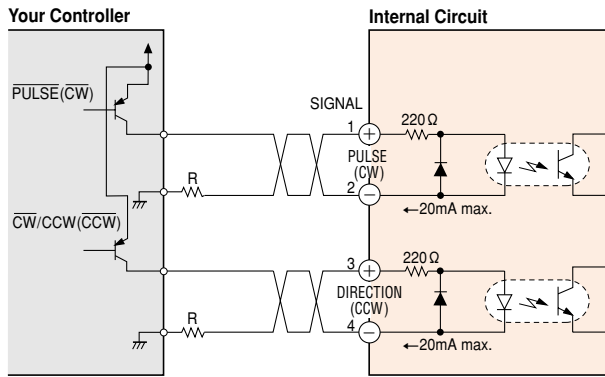

The characters indicate signals under the 1-pulse input mode, while the characters in parenthesis indicate signals under the 2-pulse input mode. The external resistance R is not needed when V_0 is 5V. When the voltage exceeds 5V, connect the external resistance R to keep input current at 20mA or less.

1-pulse Input Mode

● Pulse Signal

When the photocopier state changes from "ON" to "OFF", the motor rotates one step.

The direction of the motor's rotation is determined by the following "Rotation Direction" signal.

● Rotation Direction Signal

The "Rotation Direction" signal is input.

A "photocopier ON" signal input commands a clockwise direction rotation.

A "photocopier OFF" signal input commands a counterclockwise direction rotation.

2-pulse Input Mode (only for CSK59 □ type)

● CW Pulse Signal

When the photocopier state changes from "ON" to "OFF", the motor rotates one step in the clockwise direction.

● CCW Pulse Signal

When the photocopier state changes from "ON" to "OFF", the motor rotates one step in the counterclockwise direction.

■ Pulse Signal Characteristics

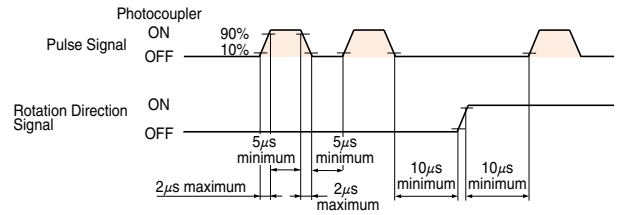

Shaded area indicates the photocopier diode is on. The motor moves when the photocopier state changes from "ON" to "OFF".

Pulse Signal Characteristics

1. The pulse voltage is 4~5V in the "photocopier ON" state, and 0~0.5V in the "photocopier OFF" state.
2. Input pulses for a pulse width is 5μs or more, the rise/ drop time is 2μs or less and pulse duty is 50% or less.
3. 10μs or more is the standard interval time for switching from CW to CCW. Note that the interval time greatly varies according to the motor and load inertia.

Pulse Signal Input Precautions

Be sure to set the signal in the "photocopier OFF" state when the pulse signal is at rest. Setting to the signal in the "photocopier ON" state will not activate the "Automatic Current Cutback" function.

● 1-pulse Input Mode

Be sure to switch the direction of rotation with the "Pulse" signal in the "photocopier OFF" state.

● 2-pulse Input Mode

Do not input CW pulses and CCW pulses at the same time.

When the "CW Pulse" signal or "CCW Pulse" signal is in the "photocopier ON" state, the input of pulses to the other will not rotate the motor normally.

2. H. OFF* (All Windings Off) Signal (*C.OFF for CSK59 □ type)

■ Input Circuit and Sample Connection

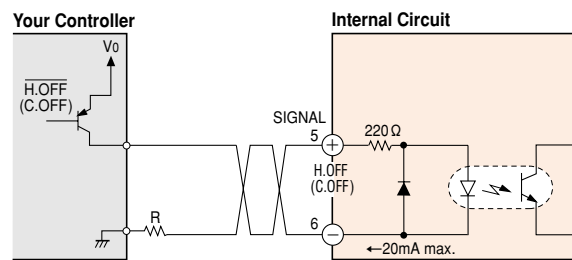

The external resistance R is not needed when V_0 is 5V. When the voltage exceeds 5V, connect the external resistance R to keep input current at 20mA or less.

1. If the "H.OFF" (or C.OFF) signal is in the "photocopier ON" state, the current does not flow through the motor and the motor shaft can be turned manually. This function can be used when the motor shaft needs external rotation or manual positioning. Be sure to set to the signal in the "photocopier OFF" state when operating the motor. For regular use, no connections are necessary. The holding torque can be set in proportion to the motor stop current set by the STOP dial.
2. Turning the "H.OFF" (or C.OFF) signal OFF does not change the excitation sequence (phase) of the motor. When the motor shaft is turned manually with H.OFF (or C.OFF) input, the shaft may turn $\pm 3.6^\circ$ from the shaft position when H.OFF (or C.OFF) is released.

3. FULL/HALF (Step Angle) Signal

Input Circuit and Sample Connection

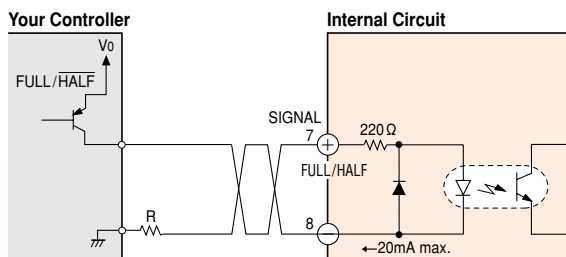

The external resistance R is not needed when V_0 is 5V. When the voltage exceeds 5V, connect the external resistance R to keep input current at 20mA or less.

1. If the "FULL/HALF" signal is in the "photocoupler ON" state half-step mode ($0.36^\circ/\text{step}$) has been selected; when it is in the "photocoupler OFF" state full-step mode ($0.72^\circ/\text{step}$) has been selected.
2. Switch the step angle when the pulse input is in the "photocoupler OFF" state. The "FULL/HALF" signal is read when the "Pulse" signal is falling, therefore switching the "FULL/HALF" signal after the pulse has fallen will not change the signal until the pulse falls again.

4. C.D.INH (Automatic Current Cutback Release) Signal

Input Circuit and Sample Connection

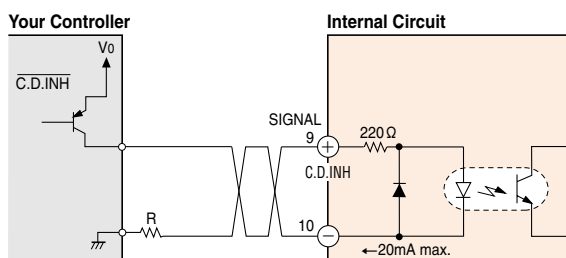

The external resistance R is not needed when V_0 is 5V. When the voltage exceeds 5V, connect the external resistance R to keep input current at 20mA or less.

1. If the "C.D.INH" signal is in the "photocoupler ON" state the "Automatic Current Cutback" function is not activated; even after the motor has stopped, current set with the RUN potentiometer will continue flowing to the motor.
2. If the "C.D.INH" signal is in the "photocoupler OFF" state the "Automatic Current Cutback" function is activated; approximately 100ms after the motor has stopped, current set with the STOP potentiometer will flow to the motor.
3. Approximately 100ms after the input pulses have stopped, the current is reduced; when the input pulse signal drops to 10Hz or below, the "Automatic Current Cutback" function works for each pulse.

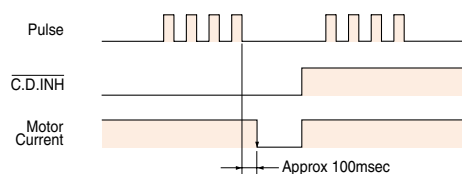

5. TIMING (Excitation Timing) Signal

Output Circuit and Sample Connection

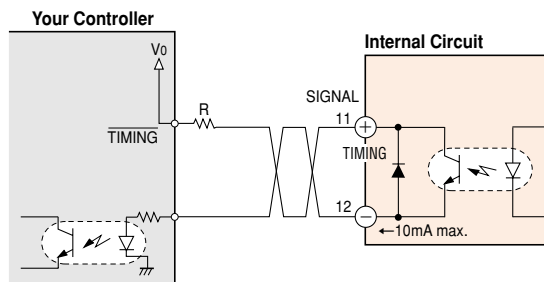

Keep the voltage between 5V and 24V and current at 10mA or less.

1. The "Excitation Timing" (TIMING) signal indicates that the excitation of the motor is in the initial state (STEP 0). Use this signal to detect the home position accurately by matching the mechanical home position of the device and the excitation home position (STEP 0) of the motor.
2. The signal is output once each time the excitation sequence returns to (STEP 0) in synchronization with input pulses. The excitation sequence is designed to complete one cycle as the motor shaft rotates 7.2° . Output is as follows:
 $0.72^\circ/\text{step}$ (Full step): 1 output per 10 pulses
 $0.36^\circ/\text{step}$ (Half step): 1 output per 20 pulses

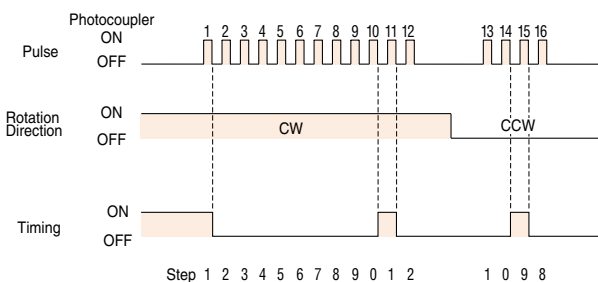

When used as indicated in the sample connection, the signal is in the "photocoupler ON" state at STEP 0.

Notes: When the power is turned ON, the excitation sequence is reset to STEP 0.

6. O.HEAT (Overheat) Output (This function is equipped only for CSK59 □ type)

Output Circuit and Sample Connection

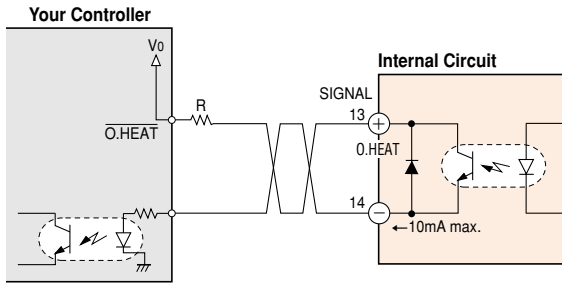

Keep the voltage between 5V and 24V and current at 10mA or less.

1. The "Overheat" (O.HEAT) signal is output to protect the driver from overheating damage when the temperature of the driver radiation plate rises abnormally due to a rise in the ambient temperature or other factors. At the same time this signal is output, the O.H. LED on the circuit board lights.
2. If the "Automatic Current Off" function is activated, the motor excitation will cease (shaft free) and the motor will come to a natural stop.
3. When the "O.HEAT" signal has been output, reconfirm the use conditions (ambient temperature, operation patterns, etc.) or take appropriate measures, such as forced cooling of the driver.
4. The "O.HEAT" signal is automatically turned off when the temperature of the driver radiation plate falls. (The O.HEAT signal returns to the "photocopler OFF" state and O.H.LED goes off.) This signal cannot be turned on and off by using external signals or by turning the power back on.

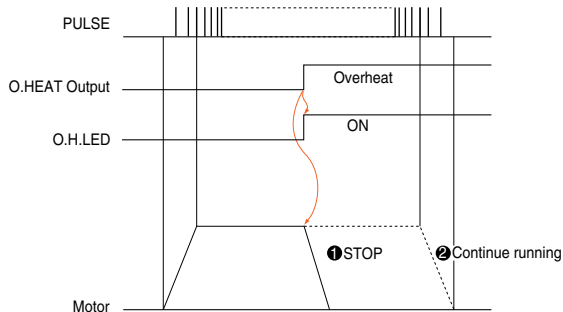

- The "Automatic Current Off" function select switch can be used to determine how the "O.HEAT" signal affects the motor's operation.
- ① Set to ACO to have the motor stop immediately.
 - ② Set to OFF to have the motor continue running.

Switching and Setting Functions (This switch is equipped only for CSK59 □ type)

1. Automatic Current Off Function

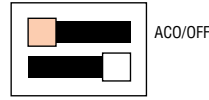

Setting the "Automatic Current Off" select switch to "ACO" (left side) activates the "Automatic Current Off" function. When the function is activated, the motor output current is automatically reduced to zero and the motor stops if the temperature of the driver radiation plate rises to 90°C (overheat). Setting this switch to "OFF" (right side) deactivates the automatic current off function. (The motor can be operated even after overheating, but it is recommended that the motor be stopped promptly upon detecting of an overheat signal.) This select switch is set to "ACO" at the factory.

2. Pulse Input Mode

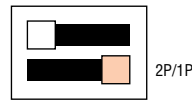

Setting the pulse input mode select switch to "1P" (right side) places the driver in 1-pulse input mode which control the motor through pulse signals and directional signals. Setting this switch to "2P" (left side) place the driver in 2-pulse input mode which control the motor through two pulse signal systems of CW and CCW pulse. The select switch is set to "1P" at the factory.

■ Adjusting the Output Current

1. Adjustment Method

The rated output current is set at the factory. When it is necessary to change the current setting, follow the procedures described below.

Connecting an ammeter

- CSK54 □, CSK56 □ Type
- CSK543 □ E-TG □, CSK564 □ E-TG □ Type

Connect a DC ammeter between the motor and pin ① of CN3 connector as shown below.

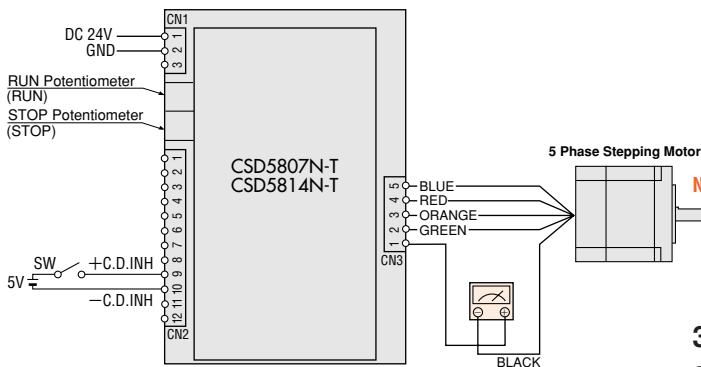

● CSK59 □ Type

Connect a DC ammeter between the motor and pin ① of "MOTOR" connector as shown below.

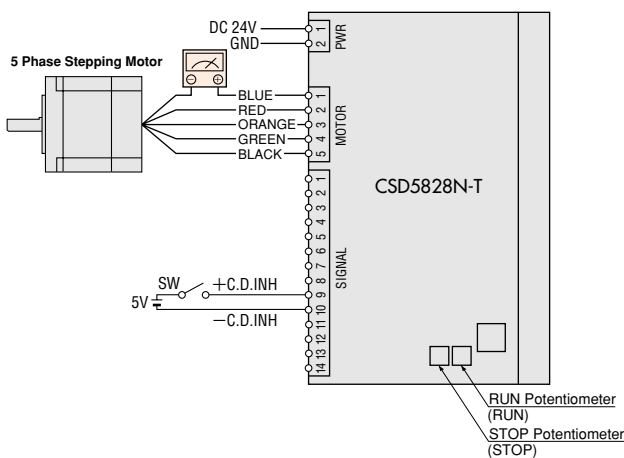

- After connecting the DC ammeter to the motor, turn on the power. (The excitation status at this point is fixed: power on reset.)
- When the power is turned on, the motor enters a 4 phase excitation state, and +directional current flows through the blue motor lead wire. (Even if 4-5phase excitation has been selected, the motor enters a 4 phase excitation state when the power is turned on. Adjust the current in this state.)
- The value measured by the ammeter represents the total current in two phases. The current for one phase is equivalent to half of the ammeter value. (When setting the current to 1.0A/phase, adjust the current level until the ammeter reads 2.0A.)

2. Adjusting the Motor Operating Current

Set "Automatic Current Cutback Release" (C.D.INH) signal to in the "photocoupler ON" state (SW:ON) when adjusting the RUN current.

- (1) Adjust the motor RUN current with the RUN potentiometer.
Adjustment Range CSD5807N-T:0.1A/phase~0.75A/phase
CSD5814N-T:0.1A/phase~1.4A/phase
CSD5828N-T:1.0A/phase~2.8A/phase

- (2) The motor operating current is set for rated current (CSD5807N-T:0.75A/phase, CSD5814N-T:1.4A/phase, CSD5828N-T:2.8A/phase) at the time of shipping, but it can be readjusted using the RUN potentiometer. The operating current can be lowered to suppress temperature rise in the motor/driver, or lower operating current in order to allow a margin for motor torque or to reduce vibration.

Note: The motor RUN current should be less than the motor rated current.

3. Adjusting The Current At Motor Standstill

Set "Automatic Current Cutback Release" (C.D.INH) signal at in the "photocoupler OFF" state (SW: OFF) when adjusting the current while the motor is stopped.

- (1) Adjust the current at motor standstill with the STOP potentiometer.
Adjustment Range CSD5807N-T:0.1A~0.56A/phase
CSD5814N-T:0.1A~1.05A/phase
CSD5828N-T:0.7A~2.3A/phase
- (2) At the time of shipping, the current at motor standstill is set for half of rated Current. (CSD5807N-T:0.75A/phase, CSD5814N-T:0.7A/phase, CSD5828N-T:1.4A/phase) The STOP potentiometer can be used to readjust the current at motor standstill to the current value required to produce enough holding torque.

$$\text{Holding Torque (N-m)} = \frac{\text{Rated Holding Torque (N-m)} \times \text{Current at Motor Standstill (A)}}{\text{Motor Rated Current (A)}}$$

STEPPING MOTORS

QSTEP

RK

5-Phase with AC Driver

CSK

5-Phase with DC Driver

PMC

NanoStep RK

5-Phase Stepping Motors

CSK

2-Phase with DC Driver

2-Phase Stepping Motors

Controller

Accessories