

**SN54LS640 THRU SN54LS642, SN54LS644, SN54LS645  
SN74LS640 THRU SN74LS642, SN74LS644, SN74LS645  
OCTAL BUS TRANSCEIVERS**

SDLS189

D2420, APRIL 1979—REVISED MARCH 1988

- SN74LS64X-1 Versions Rated at  $I_{OL}$  of 48 mA
- Bi-directional Bus Transceivers in High-Density 20-Pin Packages
- Hysteresis at Bus Inputs Improves Noise Margins
- Choice of True or Inverting Logic
- Choice of 3-State or Open-Collector Outputs

DEVICE	OUTPUT	LOGIC
'LS640	3-State	Inverting
'LS641	Open-Collector	True
'LS642	Open-Collector	Inverting
'LS644	Open-Collector	True and inverting
'LS645	3-State	True

**description**

These octal bus transceivers are designed for asynchronous two-way communication between data buses. The devices transmit data from the A bus to the B bus or from the B bus to the A bus depending upon the level at the direction control (DIR) input. The enable input ( $\bar{G}$ ) can be used to disable the device so the buses are effectively isolated.

The -1 versions of the SN74LS640 thru SN74LS642, SN74LS644, and SN74LS645 are identical to the standard versions except that the recommended maximum  $I_{OL}$  is increased to 48 milliamperes. There are no -1 versions of the SN54LS640 thru SN54LS642, SN54LS644, and SN54LS645.

The SN54LS640 thru SN54LS642, SN54LS644, and SN54LS645 are characterized for operation over the full military temperature range of  $-55^{\circ}\text{C}$  to  $125^{\circ}\text{C}$ . The SN74LS640 thru SN74LS642, SN74LS644, and SN74LS645 are characterized for operation from  $0^{\circ}\text{C}$  to  $70^{\circ}\text{C}$ .

SN54LS' . . . J PACKAGE  
SN74LS' . . . DW OR N PACKAGE  
(TOP VIEW)

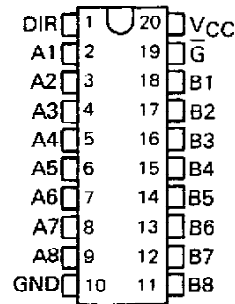

SN54LS' . . . FK PACKAGE  
(TOP VIEW)

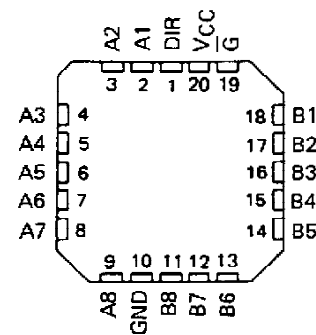

FUNCTION TABLE

CONTROL INPUTS		OPERATION		
		'LS640 'LS642	'LS641 'LS645	'LS644
L	L	B data to A bus	B data to A bus	B data to A bus
L	H	A data to B bus	A data to B bus	$\bar{A}$ data to B bus
H	X	Isolation	Isolation	Isolation

H = high level, L = low level, X = irrelevant

PRODUCTION DATA documents contain information current as of publication date. Products conform to specifications per the terms of Texas Instruments standard warranty. Production processing does not necessarily include testing of all parameters.



POST OFFICE BOX 655012 • DALLAS, TEXAS 75265

**SN54LS640 THRU SN54LS642, SN54LS644, SN54LS645  
SN74LS640 THRU SN74LS642, SN74LS644, SN74LS645  
OCTAL BUS TRANSCEIVERS**

logic symbols†

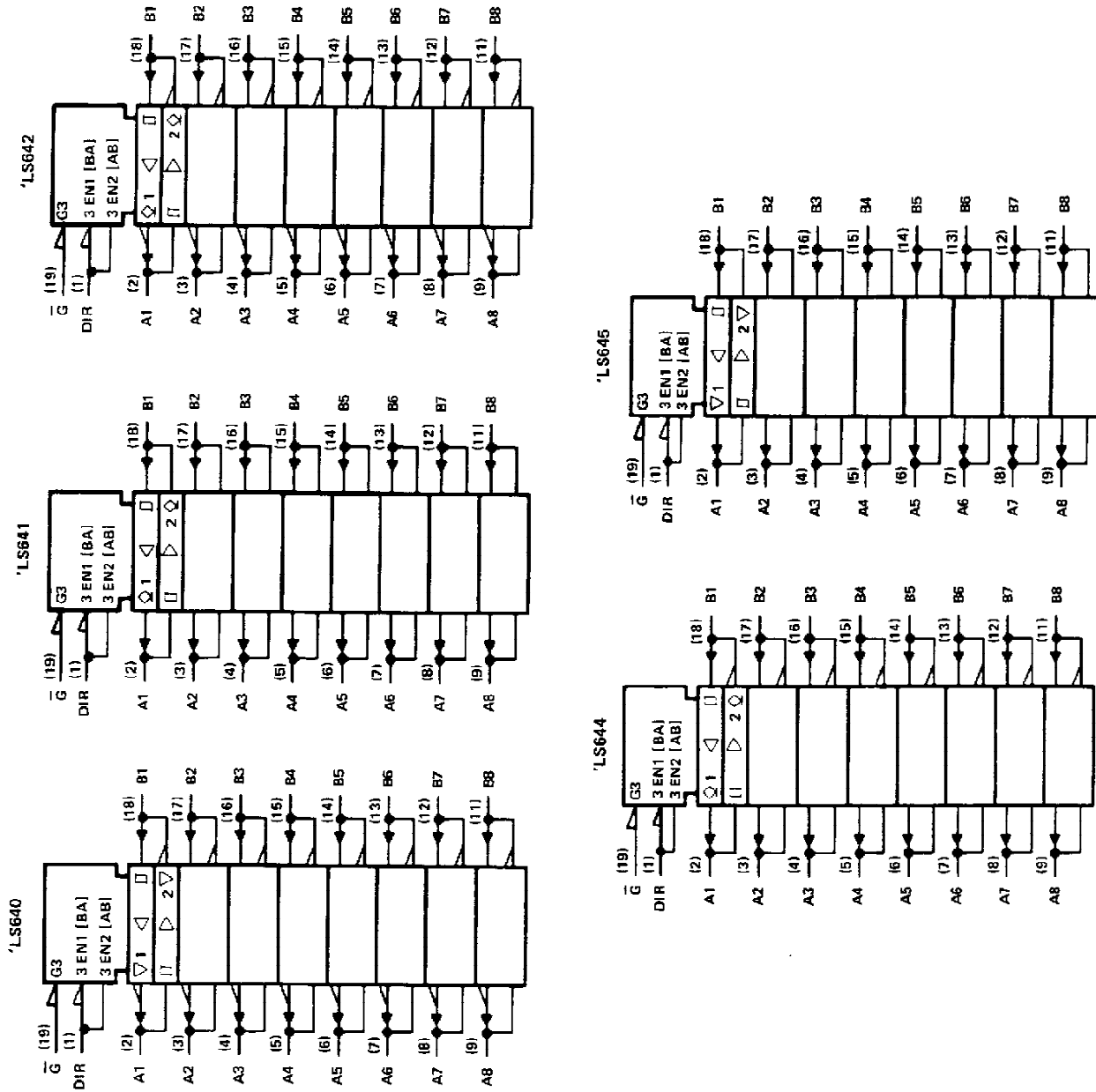

† These symbols are in accordance with ANSI/IEEE Std 91-1984 and IEC Publication 617-12. Pin numbers shown are for DW, J, and N packages.

**SN54LS640 THRU SN54LS642, SN54LS644, SN54LS645  
SN74LS640 THRU SN74LS642, SN74LS644, SN74LS645  
OCTAL BUS TRANSCEIVERS**

logic diagrams (positive logic)

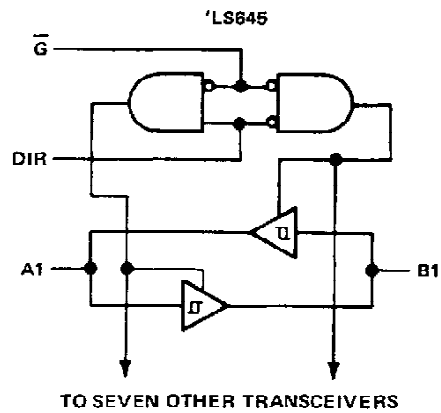
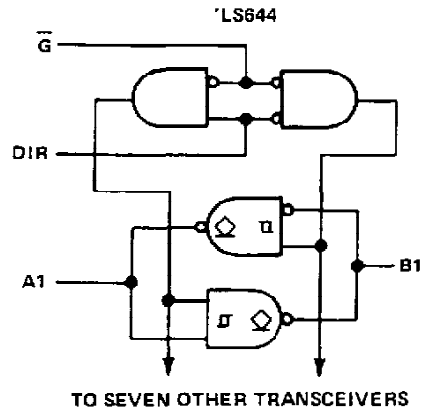
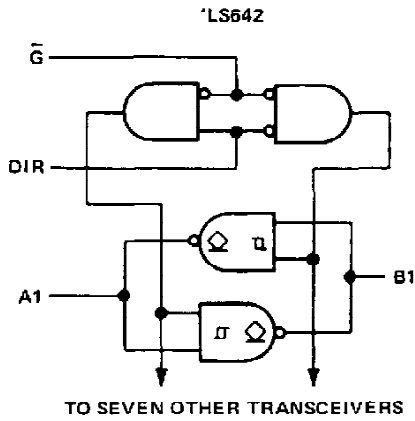
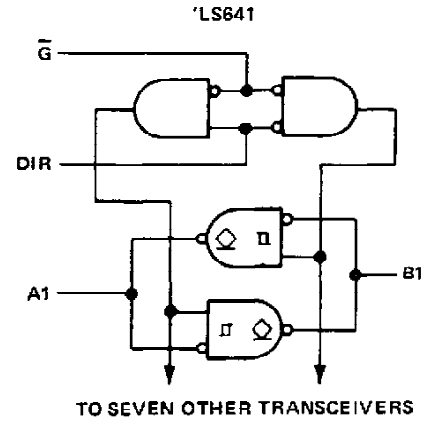
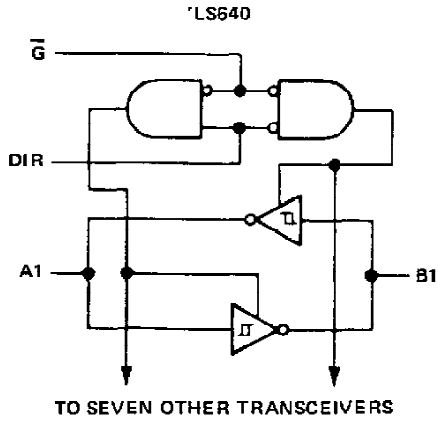

**SN54LS640, SN54LS645**  
**SN74LS640, SN74LS645**  
**OCTAL BUS TRANSCEIVERS WITH 3-STATE OUTPUTS**

**absolute maximum ratings over operating free-air temperature range (unless otherwise noted)**

Supply voltage, $V_{CC}$ (see Note 1)	7 V
Input voltage: All inputs	7 V
I/O ports	5.5 V
Operating free-air temperature range: SN54LS640, SN54LS645	-55 °C to 125 °C
SN74LS640, SN74LS645	0 °C to 70 °C
Storage temperature range	-65 °C to 150 °C

NOTE 1: Voltage values are with respect to network ground terminal.

**recommended operating conditions**

PARAMETER	SN54LS640 SN54LS645			SN74LS640 SN74LS645			UNIT
	MIN	NOM	MAX	MIN	NOM	MAX	
$V_{CC}$ Supply voltage	4.5	5	5.5	4.75	5	5.25	V
$V_{IH}$ High-level input voltage	2			2			V
$V_{IL}$ Low-level input voltage			0.5			0.6	V
$I_{OH}$ High-level output current			-12			-15	mA
$I_{OL}$ Low-level output current			12			24	mA
						48 <sup>†</sup>	
$T_A$ Operating free-air temperature	-55		125	0		70	°C

<sup>†</sup>The 48-mA limit applies for the SN74LS640-1 and SN74LS645-1 only.

**electrical characteristics over recommended operating free-air temperature range (unless otherwise noted)**

PARAMETER	TEST CONDITIONS <sup>‡</sup>	SN54LS640 SN54LS645			SN74LS640 SN74LS645			UNIT	
		MIN	TYP <sup>§</sup>	MAX	MIN	TYP <sup>§</sup>	MAX		
$V_{IK}$	$V_{CC} = \text{MIN.}$ , $I_I = -18 \text{ mA}$			-1.5			-1.5	V	
Hysteresis ( $V_{T+} - V_{T-}$ )	$V_{CC} = \text{MIN.}$ , A or B input	0.1	0.4		0.2	0.4		V	
$V_{OH}$	$V_{CC} = \text{MIN.}$ , $V_{IH} = 2 \text{ V.}$ $V_{IL} = \text{MAX.}$ $I_{OH} = -3 \text{ mA}$ $I_{OH} = \text{MAX.}$	2.4	3.4		2.4	3.4		V	
$V_{OL}$	$V_{CC} = \text{MIN.}$ , $V_{IH} = 2 \text{ V.}$ $V_{IL} = \text{MAX.}$ $I_{OL} = 12 \text{ mA}$ $I_{OL} = 24 \text{ mA}$ $I_{OL} = 48 \text{ mA}^{\#}$		0.25	0.4		0.25	0.4		
						0.35	0.5		
$I_{OZH}$	$V_{CC} = \text{MAX.}$ , $\bar{G}$ at 2 V, $V_O = 2.7 \text{ V}$			20			20	$\mu\text{A}$	
$I_{OZL}$	$V_{CC} = \text{MAX.}$ , $\bar{G}$ at 2 V, $V_O = 0.4 \text{ V}$			-0.4			-0.4	mA	
$I_I$	$V_{CC} = \text{MAX.}$	A or B		$V_I = 5.5 \text{ V}$			0.1	mA	
		DIR or $\bar{G}$		$V_I = 7 \text{ V}$			0.1		
$I_{IH}$	$V_{CC} = \text{MAX.}$ , $V_{IH} = 2.7 \text{ V}$			20			20	$\mu\text{A}$	
$I_{IL}$	$V_{CC} = \text{MAX.}$ , $V_{IL} = 0.4 \text{ V}$			-0.4			-0.4	mA	
$I_{OS}^{\#}$	$V_{CC} = \text{MAX.}$			-40			-225	mA	
$I_{CC}$	Outputs high			48	70		48	70	mA
	Outputs low	$V_{CC} = \text{MAX.}$ , Outputs open		62	90		62	90	
	Outputs at Hi-Z			64	95		64	95	

<sup>‡</sup>For conditions shown as MIN or MAX, use the appropriate value specified under recommended operating conditions.

<sup>§</sup>All typical values are at  $V_{CC} = 5 \text{ V}$ ,  $T_A = 25^\circ\text{C}$ .

<sup>¶</sup>Not more than one output should be shorted at a time, and duration of the short-circuit should not exceed one second.

<sup>\#</sup>The 48-mA condition applies for the SN74LS640-1 and SN74LS645-1 only.



**SN54LS640, SN54LS645**  
**SN74LS640, SN74LS645**  
**OCTAL BUS TRANSCEIVERS WITH 3-STATE OUTPUTS**

switching characteristics,  $V_{CC} = 5\text{ V}$ ,  $T_A = 25^\circ\text{C}$

PARAMETER	FROM (INPUT)	TO (OUTPUT)	TEST CONDITIONS	'LS640, 'LS640-1			'LS645, 'LS645-1			UNIT
				MIN	TYP	MAX	MIN	TYP	MAX	
t <sub>PLH</sub> Propagation delay time, low-to-high-level output	A	B	C <sub>L</sub> = 45 pF, R <sub>L</sub> = 667 Ω, See Note 2	6	10		8	15	ns	
	B	A		6	10		8	15		
t <sub>PHL</sub> Propagation delay time, high-to-low-level output	A	B		8	15		11	15	ns	
	B	A		8	15		11	15		
t <sub>PZL</sub> Output enable time to low level	$\bar{G}$	A		31	40		31	40	ns	
	$\bar{G}$	B		31	40		31	40		
t <sub>PZH</sub> Output enable time to high level	$\bar{G}$	A		23	40		26	40	ns	
	$\bar{G}$	B		23	40		26	40		
t <sub>PLZ</sub> Output disable time from low level	$\bar{G}$	A	15	25		15	25	ns		
	$\bar{G}$	B	15	25		15	25			
t <sub>PHZ</sub> Output disable time from high level	$\bar{G}$	A	15	25		15	25	ns		
	$\bar{G}$	B	15	25		15	25			

NOTE 2: Load circuits and voltage waveforms are shown in Section 1.

schematics of inputs and outputs

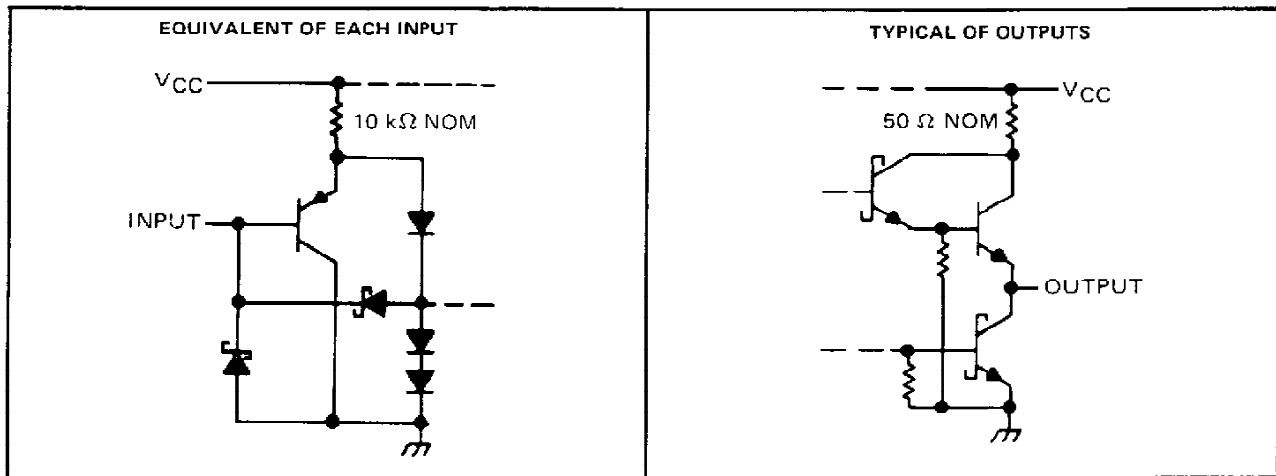

**SN54LS640, SN54LS645  
SN74LS640, SN74LS645  
OCTAL BUS TRANSCEIVERS WITH 3-STATE OUTPUTS**

**TYPICAL CHARACTERISTICS**

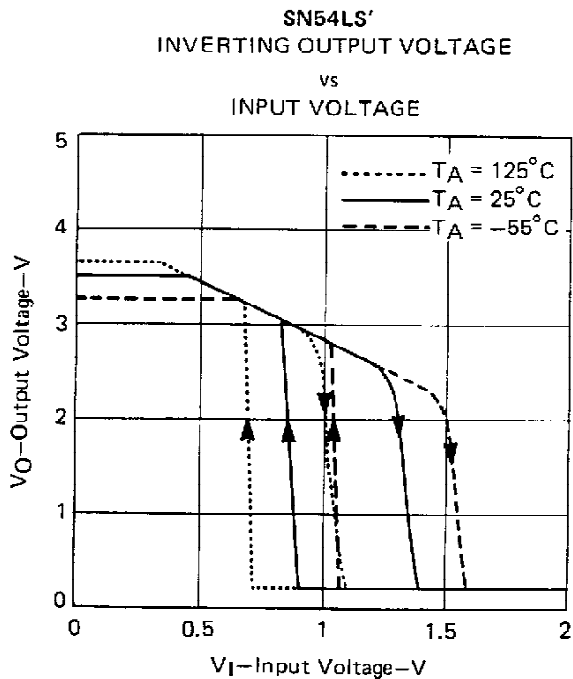

FIGURE 1

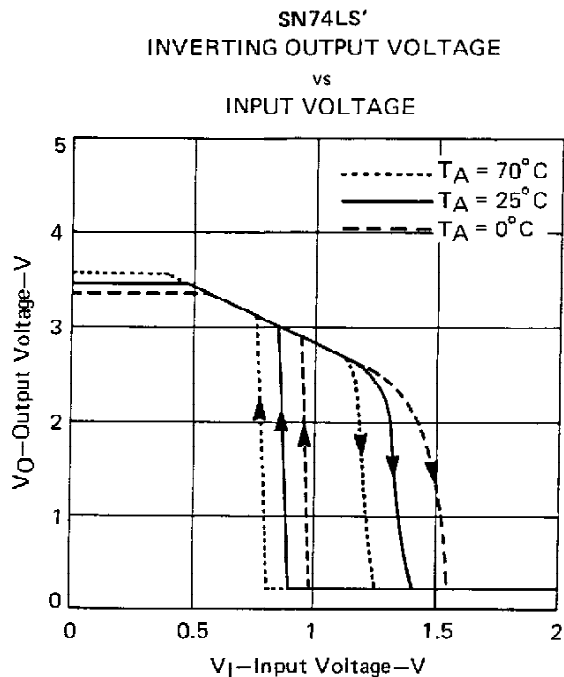

FIGURE 2

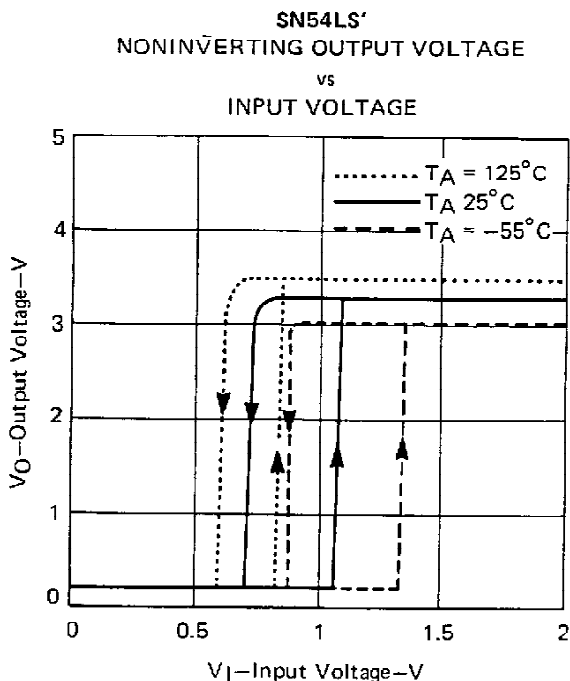

FIGURE 3

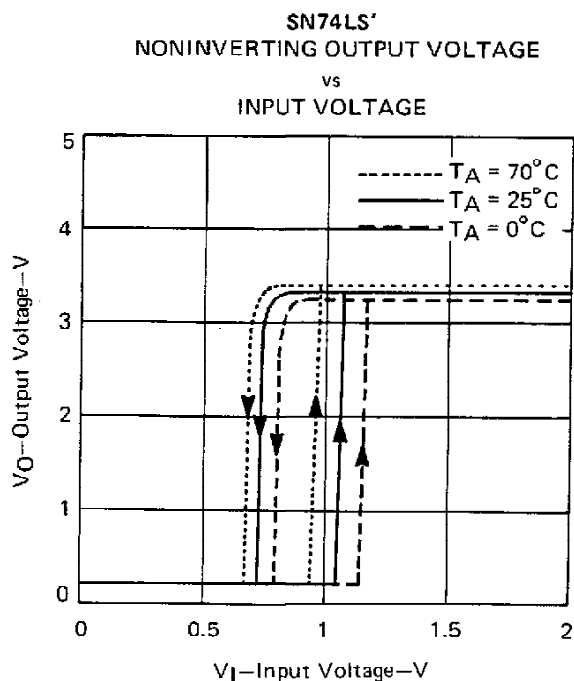

FIGURE 4



**SN54LS641, SN54LS642, SN54LS644  
SN74LS641, SN74LS642, SN74LS644  
OCTAL BUS TRANSCEIVERS WITH OPEN-COLLECTOR OUTPUTS**

**absolute maximum ratings over operating free-air temperature range (unless otherwise noted)**

Supply voltage, $V_{CC}$ (see Note 1) .....	7 V
Input voltage: All inputs and I/O ports .....	7 V
Operating free-air temperature range: SN54LS641, SN54LS642, SN54LS644 .....	-55°C to 125°C
SN74LS641, SN74LS642, SN74LS644 .....	0°C to 70°C
Storage temperature range .....	-65°C to 150°C

NOTE 1: Voltage values are with respect to network ground terminal.

**recommended operating conditions**

PARAMETER	SN54LS641 SN54LS642 SN54LS644			SN74LS641 SN74LS642 SN74LS644			UNIT
	MIN	NOM	MAX	MIN	NOM	MAX	
$V_{CC}$ Supply voltage	4.5	5	5.5	4.75	5	5.25	V
$V_{IH}$ High-level input voltage	2			2			V
$V_{IL}$ Low-level input voltage	0.5			0.6			V
$V_{OH}$ High-level output voltage	5.5			5.5			V
$I_{OL}$ Low-level output current	12			24			mA
				48§			
$T_A$ Operating free-air temperature	-55			125			°C

§ The 48 mA limit applies for the SN74LS641-1, SN74LS642-1, and SN74LS644-1 only.

**electrical characteristics over recommended operating free-air temperature range (unless otherwise noted)**

PARAMETER	TEST CONDITIONS†	SN54LS641 SN54LS642 SN54LS644			SN74LS641 SN74LS642 SN74LS644			UNIT	
		MIN	TYP‡	MAX	MIN	TYP‡	MAX		
$V_{IK}$	$V_{CC} = \text{MIN}$ , $I_I = -18 \text{ mA}$	-1.5			-1.5			V	
Hysteresis ( $V_{T+} - V_{T-}$ )	$V_{CC} = \text{MIN}$ , A or B input	0.1	0.4		0.2	0.4		V	
$I_{OH}$	$V_{CC} = \text{MIN}$ , $V_{IL} = \text{MAX}$ , $V_{IH} = 2 \text{ V}$ , $V_{OH} = 5.5 \text{ V}$	0.1			0.1			mA	
$V_{OL}$	$V_{CC} = \text{MIN}$ , $V_{IH} = 2 \text{ V}$ , $V_{IL} = \text{MAX}$	$I_{OL} = 12 \text{ mA}$	0.25	0.4	0.25	0.4	V		
		$I_{OL} = 24 \text{ mA}$			0.35	0.5			
		$I_{OL} = 48 \text{ mA}§$			0.4	0.5			
$I_I$	A or B	$V_{CC} = \text{MAX}$	$V_I = 5.5 \text{ V}$			0.1			mA
	DIR or $\bar{G}$		$V_I = 7 \text{ V}$			0.1			
$I_{IH}$	$V_{CC} = \text{MAX}$ , $V_I = 2.7 \text{ V}$	20			20			$\mu\text{A}$	
$I_{IL}$	$V_{CC} = \text{MAX}$ , $V_I = 0.4 \text{ V}$	-0.4			-0.4			mA	
$I_{CC}$	Outputs high	$V_{CC} = \text{MAX}$ , Outputs open	48	70	48	70	mA		
	Outputs low		62	90	62	90			
	Outputs at Hi-Z		64	95	64	95			

† For conditions shown as MIN or MAX, use the appropriate value specified under recommended operating conditions.

‡ All typical values are at  $V_{CC} = 5 \text{ V}$ ,  $T_A = 25^\circ\text{C}$ .

§ The 48 mA condition applies for the SN74LS641-1, SN74LS642-1, and SN74LS644-1 only.



**SN54LS641, SN54LS642, SN54LS644**  
**SN74LS641, SN74LS642, SN74LS644**  
**OCTAL BUS TRANSCEIVERS WITH OPEN-COLLECTOR OUTPUTS**

switching characteristics at  $V_{CC} = 5\text{ V}$ ,  $T_A = 25^\circ\text{C}$

PARAMETER	FROM (INPUT)	TO (OUTPUT)	'LS641, 'LS641-1		'LS642, 'LS642-1		'LS644, 'LS644-1		UNIT
			MIN	TYP	MAX	MIN	TYP	MAX	
t <sub>PLH</sub> Propagation delay time, low-to-high-level output	A	B	17	25	19	25	17	25	ns
	B	A	17	25	19	25	19	25	
t <sub>PHL</sub> Propagation delay time, high-to-low-level output	A	B	16	25	14	25	14	25	ns
	B	A	16	25	14	25	16	25	
t <sub>PLH</sub> Output disable time from low level	$\bar{G}$ , DIR	A	23	40	26	40	26	40	ns
	$\bar{G}$ , DIR	B	25	40	28	40	25	40	
t <sub>PHL</sub> Output enable time from high level	$\bar{G}$ , DIR	A	34	50	43	60	43	60	ns
	$\bar{G}$ , DIR	B	37	50	39	60	37	50	

TEST CONDITIONS  
 $C_L = 45\text{ pF}$ ,  
 $R_L = 667\ \Omega$ ,  
 See Note 2

NOTE 2: Load circuits and voltage waveforms are shown in Section 1.

schematics of inputs and outputs

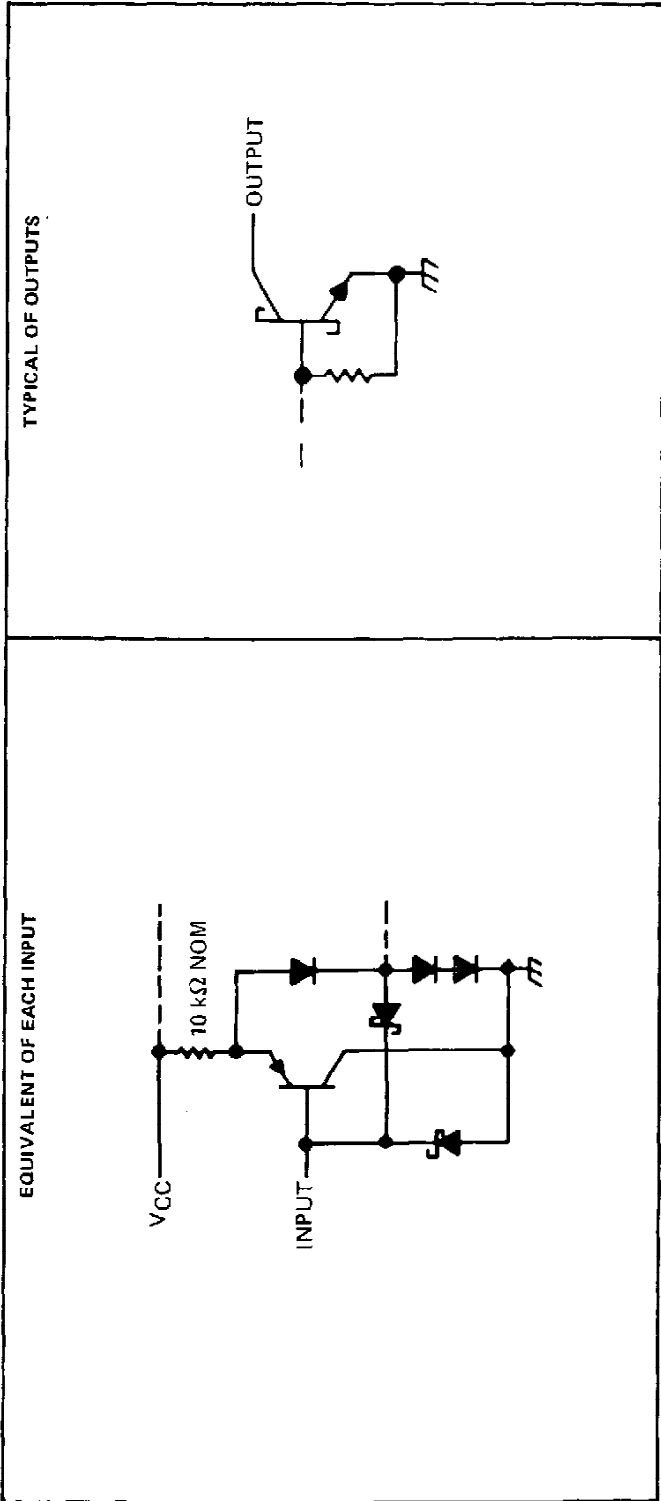



## IMPORTANT NOTICE

Texas Instruments (TI) reserves the right to make changes to its products or to discontinue any semiconductor product or service without notice, and advises its customers to obtain the latest version of relevant information to verify, before placing orders, that the information being relied on is current.

TI warrants performance of its semiconductor products and related software to the specifications applicable at the time of sale in accordance with TI's standard warranty. Testing and other quality control techniques are utilized to the extent TI deems necessary to support this warranty. Specific testing of all parameters of each device is not necessarily performed, except those mandated by government requirements.

Certain applications using semiconductor products may involve potential risks of death, personal injury, or severe property or environmental damage ("Critical Applications").

TI SEMICONDUCTOR PRODUCTS ARE NOT DESIGNED, INTENDED, AUTHORIZED, OR WARRANTED TO BE SUITABLE FOR USE IN LIFE-SUPPORT APPLICATIONS, DEVICES OR SYSTEMS OR OTHER CRITICAL APPLICATIONS.

Inclusion of TI products in such applications is understood to be fully at the risk of the customer. Use of TI products in such applications requires the written approval of an appropriate TI officer. Questions concerning potential risk applications should be directed to TI through a local SC sales office.

In order to minimize risks associated with the customer's applications, adequate design and operating safeguards should be provided by the customer to minimize inherent or procedural hazards.

TI assumes no liability for applications assistance, customer product design, software performance, or infringement of patents or services described herein. Nor does TI warrant or represent that any license, either express or implied, is granted under any patent right, copyright, mask work right, or other intellectual property right of TI covering or relating to any combination, machine, or process in which such semiconductor products or services might be or are used.

## **IMPORTANT NOTICE**

Texas Instruments (TI) reserves the right to make changes to its products or to discontinue any semiconductor product or service without notice, and advises its customers to obtain the latest version of relevant information to verify, before placing orders, that the information being relied on is current.

TI warrants performance of its semiconductor products and related software to the specifications applicable at the time of sale in accordance with TI's standard warranty. Testing and other quality control techniques are utilized to the extent TI deems necessary to support this warranty. Specific testing of all parameters of each device is not necessarily performed, except those mandated by government requirements.

Certain applications using semiconductor products may involve potential risks of death, personal injury, or severe property or environmental damage ("Critical Applications").

**TI SEMICONDUCTOR PRODUCTS ARE NOT DESIGNED, INTENDED, AUTHORIZED, OR WARRANTED TO BE SUITABLE FOR USE IN LIFE-SUPPORT APPLICATIONS, DEVICES OR SYSTEMS OR OTHER CRITICAL APPLICATIONS.**

Inclusion of TI products in such applications is understood to be fully at the risk of the customer. Use of TI products in such applications requires the written approval of an appropriate TI officer. Questions concerning potential risk applications should be directed to TI through a local SC sales office.

In order to minimize risks associated with the customer's applications, adequate design and operating safeguards should be provided by the customer to minimize inherent or procedural hazards.

TI assumes no liability for applications assistance, customer product design, software performance, or infringement of patents or services described herein. Nor does TI warrant or represent that any license, either express or implied, is granted under any patent right, copyright, mask work right, or other intellectual property right of TI covering or relating to any combination, machine, or process in which such semiconductor products or services might be or are used.