

TL061, TL061A, TL061B, TL061Y, TL062, TL062A TL062B, TL062Y, TL064, TL064A, TL064B, TL064Y LOW-POWER JFET-INPUT OPERATIONAL AMPLIFIERS

SLOS078D – NOVEMBER 1978 – REVISED MAY 1997

- Very Low Power Consumption
- Typical Supply Current . . . 200 μ A (per Amplifier)
- Wide Common-Mode and Differential Voltage Ranges
- Low Input Bias and Offset Currents
- Common-Mode Input Voltage Range Includes V_{CC+}
- Output Short-Circuit Protection
- High Input impedance . . . JFET-Input Stage
- Internal Frequency Compensation
- Latch-Up-Free Operation
- High Slew Rate . . . 3.5 V/ μ s Typ

description

The JFET-input operational amplifiers of the TL06_ series are designed as low-power versions of the TL08_ series amplifiers. They feature high input impedance, wide bandwidth, high slew rate, and low input offset and bias currents. The TL06_ series feature the same terminal assignments as the TL07_ and TL08_ series. Each of these JFET-input operational amplifiers incorporates well-matched, high-voltage JFET and bipolar transistors in a monolithic integrated circuit.

The C-suffix devices are characterized for operation from 0°C to 70°C. The I-suffix devices are characterized for operation from –40°C to 85°C, and the M-suffix devices are characterized for operation over the full military temperature range of –55°C to 125°C.

AVAILABLE OPTIONS

T _A	V _{IOmax} AT 25°C	PACKAGED DEVICES					CHIP FORM (Y)
		SMALL OUTLINE (D008)†	SMALL OUTLINE (D014)†	PLASTIC DIP (N)	PLASTIC DIP (P)	TSSOP (PW)	
0°C to 70°C	15mV 6mV 3mV	TL061CD TL061ACD TL061BCD			TL061CP TL061ACP TL061BCP	TL061CPW	TL061Y
	15mV 6mV 3mV	TL062CD TL062ACD TL062BCD			TL062CP TL062ACP TL062BCP	TL062CPW	TL062Y
	15mV 6mV 3mV		TL064CD TL064ACD TL064BCD	TL064CN TL064ACN TL064BCN		TL064CPW	TL064Y

T _A	V _{IOmax} AT 25°C	PACKAGE								
		SMALL OUTLINE (D008)†	SMALL OUTLINE (D014)†	CHIP CARRIER (FK)	CERAMIC DIP (J)	CERAMIC DIP (JG)	PLASTIC DIP (N)	PLASTIC DIP (P)	FLAT PACK (U)	FLAT PACK (W)
–40°C to 85°C	6mV	TL061ID TL062ID	TL064ID				TL064IN	TL061IP TL062IP		
–55°C to 125°C	6mV 6mV 9mV			TL061MFK TL062MFK TL064MFK	TL064MJ	TL061MJG TL062MJG			TL061MU TL062MU	TL064MW

† The D package is available taped and reeled. Add the suffix R to the device type (e.g., TL061CDR).



Please be aware that an important notice concerning availability, standard warranty, and use in critical applications of Texas Instruments semiconductor products and disclaimers thereto appears at the end of this data sheet.

PRODUCTION DATA information is current as of publication date. Products conform to specifications per the terms of Texas Instruments standard warranty. Production processing does not necessarily include testing of all parameters.

**TEXAS
INSTRUMENTS**

POST OFFICE BOX 655303 • DALLAS, TEXAS 75265

Copyright © 1997, Texas Instruments Incorporated

**TL061, TL061A, TL061B, TL061Y, TL062, TL062A
 TL062B, TL062Y, TL064, TL064A, TL064B, TL064Y
 LOW-POWER JFET-INPUT OPERATIONAL AMPLIFIERS**

SLOS078D – NOVEMBER 1978 – REVISED MAY 1997

**TL061, TL061A, TL061B
 D, JG, P, OR PW PACKAGE
 (TOP VIEW)**

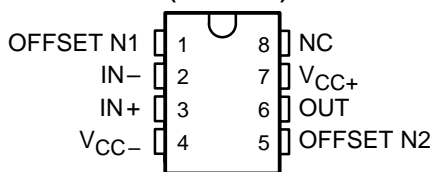

**TL061 ... U PACKAGE
 (TOP VIEW)**

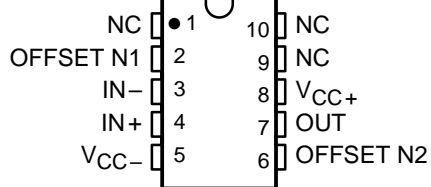

**TL062, TL062A, TL062B
 D, JG, P, OR PW PACKAGE
 (TOP VIEW)**

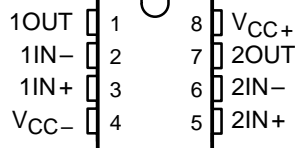

**TL062 ... U PACKAGE
 (TOP VIEW)**

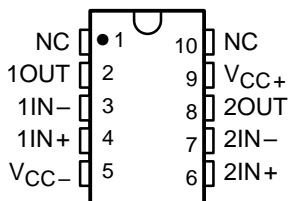

**TL064 ... D, J, N, PW, OR W PACKAGE
 TL064A, TL064B ... D OR N PACKAGE
 (TOP VIEW)**

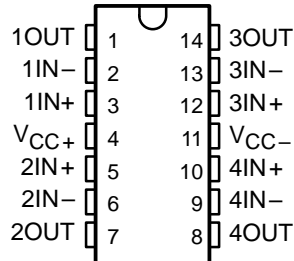

NC – No internal connection

**TL061 ... FK PACKAGE
 (TOP VIEW)**

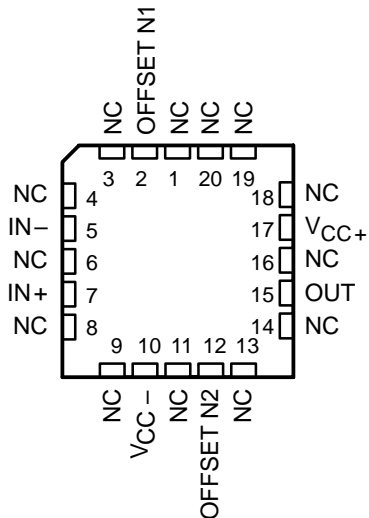

NC – No internal connection

**TL062 ... FK PACKAGE
 (TOP VIEW)**

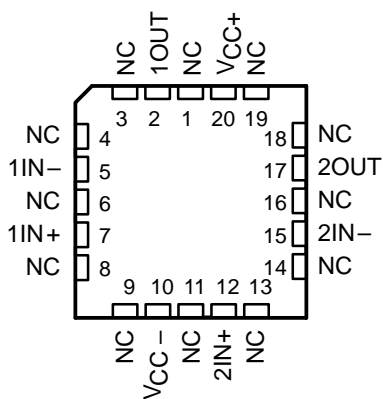

**TL064 ... FK PACKAGE
 (TOP VIEW)**

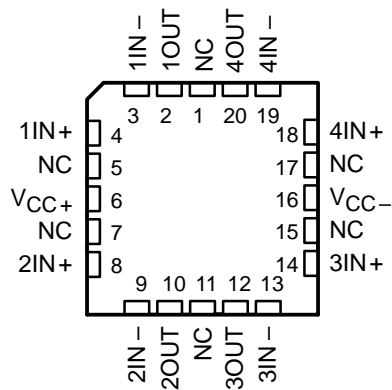

TL061, TL061A, TL061B, TL061Y, TL062, TL062A
 TL062B, TL062Y, TL064, TL064A, TL064B, TL064Y
LOW-POWER JFET-INPUT OPERATIONAL AMPLIFIERS

SLOS078D – NOVEMBER 1978 – REVISED MAY 1997

symbol (each amplifier)

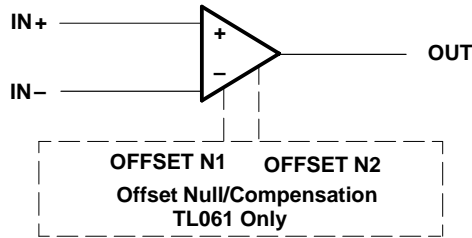

schematic (each amplifier)

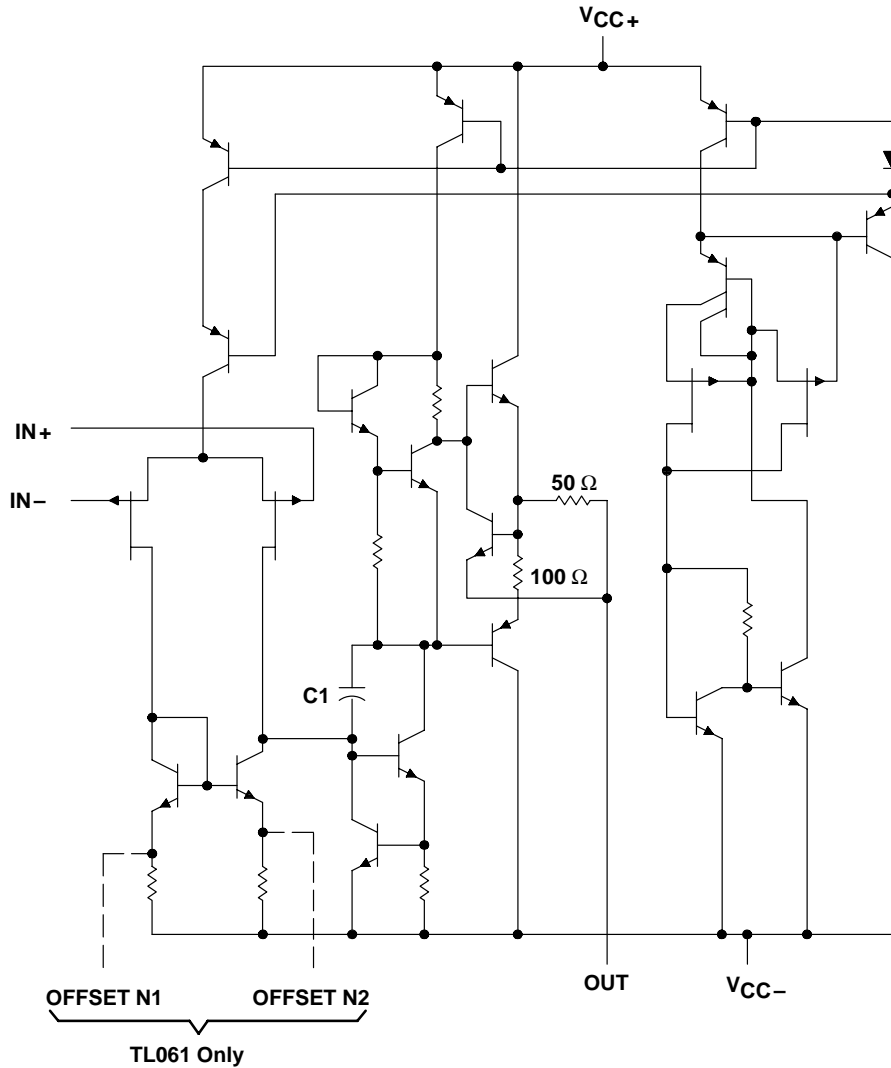

C1 = 10 pF on TL061, TL062, and TL064
 Component values shown are nominal.

**TL061, TL061A, TL061B, TL061Y, TL062, TL062A
 TL062B, TL062Y, TL064, TL064A, TL064B, TL064Y
 LOW-POWER JFET-INPUT OPERATIONAL AMPLIFIERS**
 SLOS078D – NOVEMBER 1978 – REVISED MAY 1997

TL061Y chip information

This chip, when properly assembled, displays characteristics similar to the TL061. Thermal compression or ultrasonic bonding may be used on the doped-aluminum bonding pads. The chips may be mounted with conductive epoxy or a gold-silicon preform.

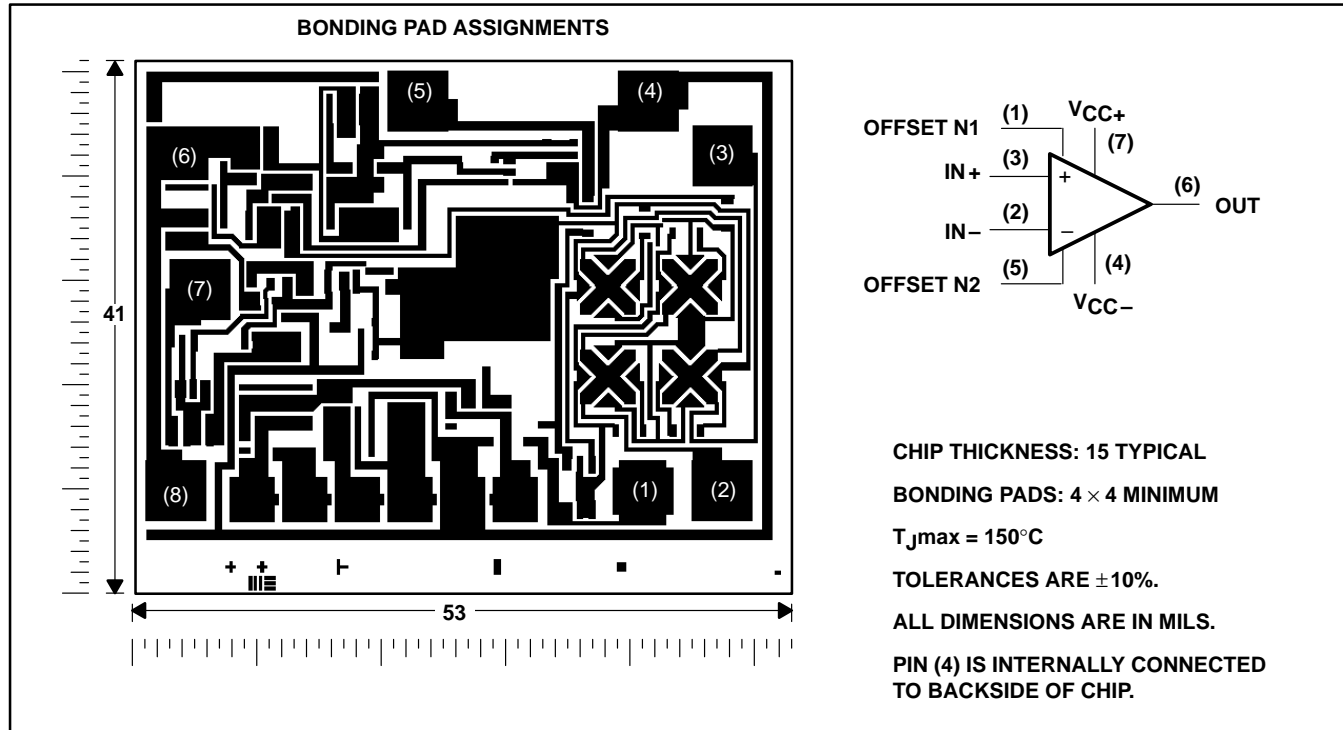

TL061, TL061A, TL061B, TL061Y, TL062, TL062A
 TL062B, TL062Y, TL064, TL064A, TL064B, TL064Y
LOW-POWER JFET-INPUT OPERATIONAL AMPLIFIERS

SLOS078D – NOVEMBER 1978 – REVISED MAY 1997

TL062Y chip information

This chip, when properly assembled, displays characteristics similar to the TL062. Thermal compression or ultrasonic bonding may be used on the doped-aluminum bonding pads. The chips may be mounted with conductive epoxy or a gold-silicon preform.

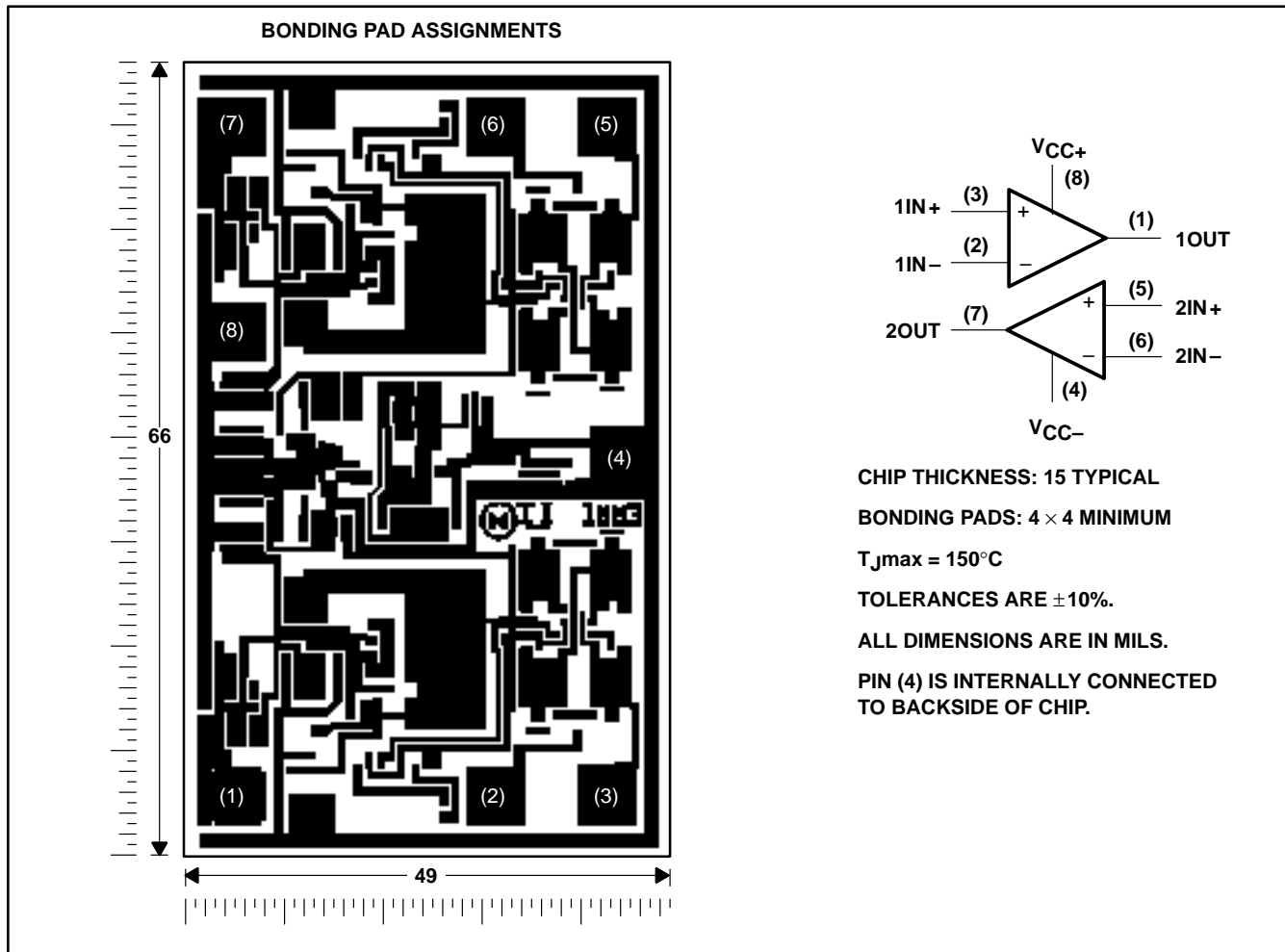

**TL061, TL061A, TL061B, TL061Y, TL062, TL062A
 TL062B, TL062Y, TL064, TL064A, TL064B, TL064Y
 LOW-POWER JFET-INPUT OPERATIONAL AMPLIFIERS**
 SLOS078D – NOVEMBER 1978 – REVISED MAY 1997

TL064Y chip information

This chip, when properly assembled, displays characteristics similar to the TL064. Thermal compression or ultrasonic bonding may be used on the doped-aluminum bonding pads. The chips may be mounted with conductive epoxy or a gold-silicon preform.

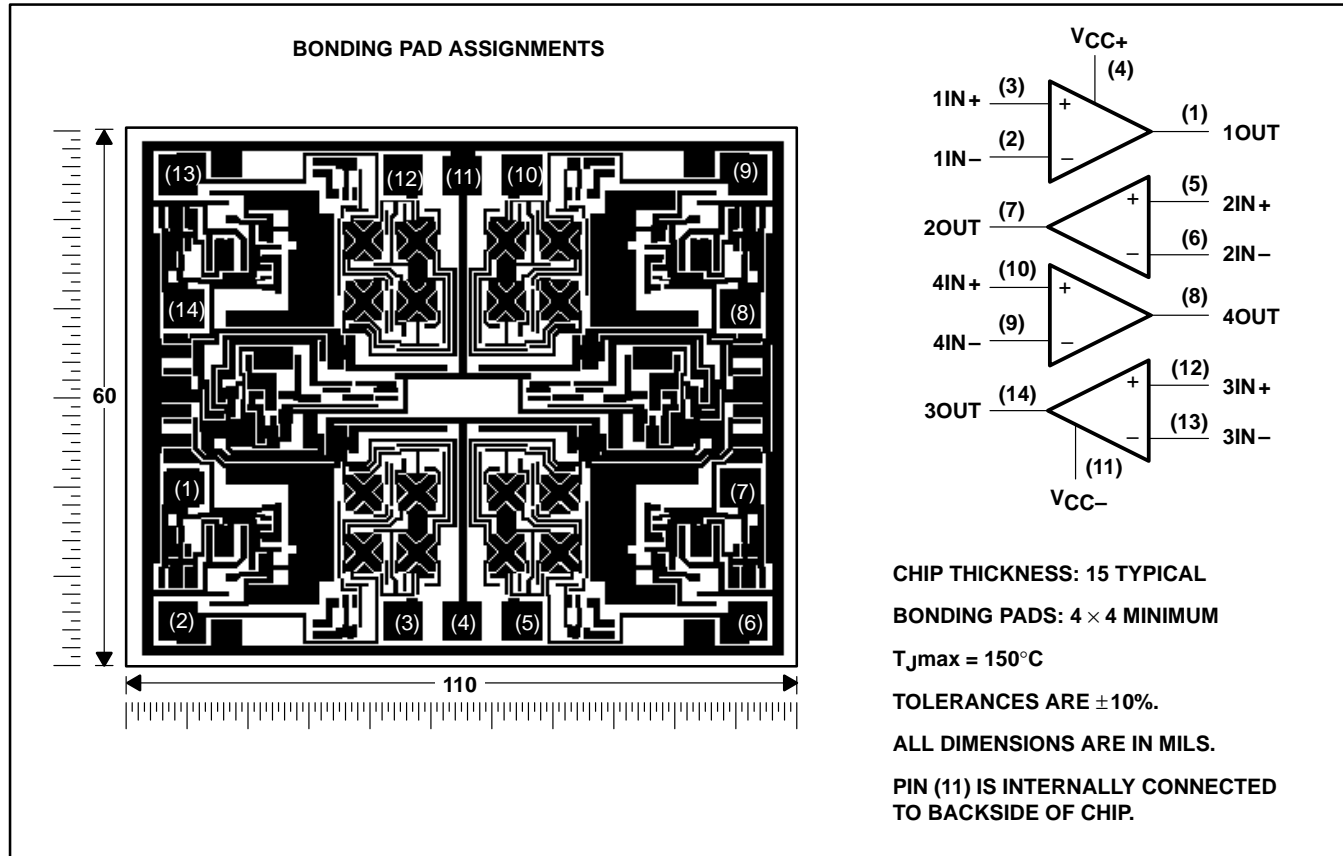

**TL061, TL061A, TL061B, TL061Y, TL062, TL062A
TL062B, TL062Y, TL064, TL064A, TL064B, TL064Y
LOW-POWER JFET-INPUT OPERATIONAL AMPLIFIERS**

SLOS078D – NOVEMBER 1978 – REVISED MAY 1997

absolute maximum ratings over operating free-air temperature range (unless otherwise noted)†

	TL06_C TL06_AC TL06_BC	TL06_I	TL06_M	UNIT
Supply voltage, V_{CC+} (see Note 1)	18	18	18	V
Supply voltage, V_{CC-} (see Note 1)	-18	-18	-18	V
Differential input voltage, V_{ID} (see Note 2)	± 30	± 30	± 30	V
Input voltage, V_I (see Notes 1 and 3)	± 15	± 15	± 15	V
Duration of output short circuit (see Note 4)	unlimited	unlimited	unlimited	
Continuous total dissipation	See Dissipation Rating Table			
Operating free-air temperature range	0 to 70	-40 to 85	-55 to 125	°C
Storage temperature range	-65 to 150	-65 to 150	-65 to 150	°C
Case temperature for 60 seconds	FK package		260	°C
Lead temperature 1,6 mm (1/16 inch) from case for 60 seconds	J, JG, U, or W package		300	°C
Lead temperature 1,6 mm (1/16 inch) from case for 10 seconds	D, N, P, or PW package	260	260	°C

† Stresses beyond those listed under “absolute maximum ratings” may cause permanent damage to the device. These are stress ratings only, and functional operation of the device at these or any other conditions beyond those indicated under “recommended operating conditions” is not implied. Exposure to absolute-maximum-rated conditions for extended periods may affect device reliability.

- NOTES:
1. All voltage values except differential voltages are with respect to the midpoint between V_{CC+} and V_{CC-} .
 2. Differential voltages are at $IN+$ with respect to $IN-$.
 3. The magnitude of the input voltage must never exceed the magnitude of the supply voltage or 15 V, whichever is less.
 4. The output may be shorted to ground or to either supply. Temperature and/or supply voltages must be limited to ensure that the dissipation rating is not exceeded.

DISSIPATION RATING TABLE

PACKAGE	$T_A \leq 25^\circ\text{C}$ POWER RATING	DERATING FACTOR	DERATE ABOVE T_A	$T_A = 70^\circ\text{C}$ POWER RATING	$T_A = 85^\circ\text{C}$ POWER RATING	$T_A = 125^\circ\text{C}$ POWER RATING
D (8 pin)	680 mW	5.8 mW/°C	33°C	465 mW	378 mW	N/A
D (14 pin)	680 mW	7.6 mW/°C	60°C	604 mW	490 mW	N/A
FK	680 mW	11.0 mW/°C	88°C	680 mW	680 mW	273 mW
J	680 mW	11.0 mW/°C	88°C	680 mW	680 mW	273 mW
JG	680 mW	8.4 mW/°C	69°C	672 mW	546 mW	210 mW
N	680 mW	9.2 mW/°C	76°C	680 mW	597 mW	N/A
P	680 mW	8.0 mW/°C	65°C	640 mW	520 mW	N/A
PW (8 pin)	525 mW	4.2 mW/°C	25°C	336 mW	N/A	N/A
PW (14 pin)	700 mW	5.6 mW/°C	25°C	448 mW	N/A	N/A
U	675 mW	5.4 mW/°C	25°C	432 mW	351 mW	135 mW
W	680 mW	8.0 mW/°C	65°C	640 mW	520 mW	200 mW



electrical characteristics, $V_{CC\pm} = \pm 15$ V (unless otherwise noted)

PARAMETER	TEST CONDITIONS†		TL061C TL062C TL064C			TL061AC TL062AC TL064AC			TL061BC TL062BC TL064BC			TL061I TL062I TL064I			UNIT
			MIN	TYP	MAX	MIN	TYP	MAX	MIN	TYP	MAX	MIN	TYP	MAX	
V_{IO} Input offset voltage	$V_O = 0,$ $R_S = 50 \Omega$	$T_A = 25^\circ\text{C}$	3	15		3	6		2	3		3	6	mV	
		$T_A = \text{Full range}$		20		7.5		5		9					
αV_{IO} Temperature coefficient of input offset voltage	$V_O = 0,$ $T_A = \text{Full range}$	$R_S = 50 \Omega,$	10			10			10			10			$\mu\text{V}/^\circ\text{C}$
I_{IO} Input offset current	$V_O = 0$	$T_A = 25^\circ\text{C}$	5	200		5	100		5	100		5	100	pA	
		$T_A = \text{Full range}$	5			3			3			10			nA
I_{IB} Input bias current‡	$V_O = 0$	$T_A = 25^\circ\text{C}$	30	400		30	200		30	200		30	200	pA	
		$T_A = \text{Full range}$	10			7			7			20			nA
V_{ICR} Common-mode input voltage range	$T_A = 25^\circ\text{C}$		± 11	-12 to 15		± 11	-12 to 15		± 11	-12 to 15		± 11	-12 to 15	V	
V_{OM} Maximum peak output voltage swing	$R_L = 10 \text{ k}\Omega,$ $T_A = 25^\circ\text{C}$		± 10	± 13.5		± 10	± 13.5		± 10	± 13.5		± 10	± 13.5	V	
	$R_L \geq 10 \text{ k}\Omega,$ $T_A = \text{Full range}$		± 10			± 10			± 10			± 10			
A_{VD} Large-signal differential voltage amplification	$V_O = \pm 10 \text{ V},$ $R_L \geq 10 \text{ k}\Omega$	$T_A = 25^\circ\text{C}$	3	6		4	6		4	6		4	6	V/mV	
		$T_A = \text{Full range}$	3			4			4			4			
B_1 Unity-gain bandwidth	$R_L = 10 \text{ k}\Omega,$ $T_A = 25^\circ\text{C}$		1			1			1			1			MHz
r_i Input resistance	$T_A = 25^\circ\text{C}$		10^{12}			10^{12}			10^{12}			10^{12}			Ω
CMRR Common-mode rejection ratio	$V_{IC} = V_{ICRmin},$ $R_S = 50 \Omega,$ $V_O = 0,$ $T_A = 25^\circ\text{C}$		70	86		80	86		80	86		80	86	dB	
k_{SVR} Supply-voltage rejection ratio ($\Delta V_{CC\pm}/\Delta V_{IO}$)	$V_{CC} = \pm 9 \text{ V to } \pm 15 \text{ V},$ $V_O = 0,$ $R_S = 50 \Omega,$ $T_A = 25^\circ\text{C}$		70	95		80	95		80	95		80	95	dB	
P_D Total power dissipation (each amplifier)	$V_O = 0,$ No load	$T_A = 25^\circ\text{C},$	6	7.5		6	7.5		6	7.5		6	7.5	mW	
I_{CC} Supply current (each amplifier)	$V_O = 0,$ No load	$T_A = 25^\circ\text{C},$	200	250		200	250		200	250		200	250	μA	
V_{O1}/V_{O2} Crosstalk attenuation	$A_{VD} = 100,$ $T_A = 25^\circ\text{C}$		120			120			120			120			dB

† All characteristics are measured under open-loop conditions with zero common-mode input voltage unless otherwise specified. Full range for T_A is 0°C to 70°C for TL06_C, TL06_AC, and TL06_BC and -40°C to 85°C for TL06_I.

‡ Input bias currents of a FET-input operational amplifier are normal junction reverse currents, which are temperature sensitive as shown in Figure 15. Pulse techniques must be used that will maintain the junction temperature as close to the ambient temperature as possible.

**TL061, TL061A, TL061B, TL061Y, TL062, TL062A
TL062B, TL062Y, TL064, TL064A, TL064B, TL064Y
LOW-POWER JFET-INPUT OPERATIONAL AMPLIFIERS**

SLOS078D – NOVEMBER 1978 – REVISED MAY 1997

electrical characteristics, $V_{CC\pm} = \pm 15$ V (unless otherwise noted)

PARAMETER	TEST CONDITIONS†	TL061M TL062M			TL064M			UNIT
		MIN	TYP	MAX	MIN	TYP	MAX	
V_{IO} Input offset voltage	$V_O = 0$, $R_S = 50 \Omega$ $T_A = 25^\circ\text{C}$ $T_A = -55^\circ\text{C to } 125^\circ\text{C}$		3	6		3	9	mV
				9			15	
α_{VIO} Temperature coefficient of input offset voltage	$V_O = 0$, $R_S = 50 \Omega$, $T_A = -55^\circ\text{C to } 125^\circ\text{C}$		10			10		$\mu\text{V}/^\circ\text{C}$
I_{IO} Input offset current	$V_O = 0$ $T_A = 25^\circ\text{C}$ $T_A = -55^\circ\text{C to } 125^\circ\text{C}$		5	100		5	100	pA
				20			20	nA
I_{IB} Input bias current‡	$V_O = 0$ $T_A = 25^\circ\text{C}$ $T_A = -55^\circ\text{C to } 125^\circ\text{C}$		30	200		30	200	pA
				50			50	nA
V_{ICR} Common-mode input voltage range	$T_A = 25^\circ\text{C}$	± 11.5	-12 to 15		± 11.5	-12 to 15		V
V_{OM} Maximum peak output voltage swing	$R_L = 10 \text{ k}\Omega$, $T_A = 25^\circ\text{C}$	± 10	± 13.5		± 10	± 13.5		V
	$R_L \geq 10 \text{ k}\Omega$, $T_A = -55^\circ\text{C to } 125^\circ\text{C}$	± 10			± 10			
A_{VD} Large-signal differential voltage amplification	$V_O = \pm 10 \text{ V}$, $R_L \geq 10 \text{ k}\Omega$ $T_A = 25^\circ\text{C}$ $T_A = -55^\circ\text{C to } 125^\circ\text{C}$		4	6		4	6	V/mV
			4			4		
B_1 Unity-gain bandwidth	$R_L = 10 \text{ k}\Omega$, $T_A = 25^\circ\text{C}$							MHz
r_i Input resistance	$T_A = 25^\circ\text{C}$		10^{12}			10^{12}		Ω
CMRR Common-mode rejection ratio	$V_{IC} = V_{ICRmin}$, $V_O = 0$, $R_S = 50 \Omega$, $T_A = 25^\circ\text{C}$	80	86		80	86		dB
k_{SVR} Supply-voltage rejection ratio ($\Delta V_{CC\pm}/\Delta V_{IO}$)	$V_{CC} = \pm 9 \text{ V to } \pm 15 \text{ V}$, $R_S = 50 \Omega$, $T_A = 25^\circ\text{C}$, $V_O = 0$	80	95		80	95		dB
P_D Total power dissipation (each amplifier)	$V_O = 0$, No load $T_A = 25^\circ\text{C}$		6	7.5		6	7.5	mW
I_{CC} Supply current (each amplifier)	$V_O = 0$, No load $T_A = 25^\circ\text{C}$		200	250		200	250	μA
V_{O1}/V_{O2} Crosstalk attenuation	$A_{VD} = 100$, $T_A = 25^\circ\text{C}$		120			120		dB

† All characteristics are measured under open-loop conditions with zero common-mode voltage unless otherwise specified.

‡ Input bias currents of a FET-input operational amplifier are normal junction reverse currents, which are temperature sensitive as shown in Figure 15. Pulse techniques must be used that maintain the junction temperature as close to the ambient temperature as possible.

operating characteristics, $V_{CC\pm} = \pm 15$ V, $T_A = 25^\circ\text{C}$

PARAMETER	TEST CONDITIONS	MIN	TYP	MAX	UNIT
SR Slew rate at unity gain (see Note 5)	$V_I = 10 \text{ V}$, $C_L = 100 \text{ pF}$, $R_L = 10 \text{ k}\Omega$, See Figure 1	1.5	3.5		V/ μs
t_r Rise time	$V_I = 20 \text{ V}$, $C_L = 100 \text{ pF}$, $R_L = 10 \text{ k}\Omega$, See Figure 1		0.2		μs
Overshoot factor			10%		
V_n Equivalent input noise voltage	$R_S = 20 \Omega$, $f = 1 \text{ kHz}$		42		nV/ $\sqrt{\text{Hz}}$

NOTE 5: Slew rate at $-55^\circ\text{C to } 125^\circ\text{C}$ is 0.7 V/ μs min.



**TL061, TL061A, TL061B, TL061Y, TL062, TL062A
TL062B, TL062Y, TL064, TL064A, TL064B, TL064Y
LOW-POWER JFET-INPUT OPERATIONAL AMPLIFIERS**

SLOS078D – NOVEMBER 1978 – REVISED MAY 1997

electrical characteristics, $V_{CC\pm} = \pm 15\text{ V}$, $T_A = 25^\circ\text{C}$ (unless otherwise noted)

PARAMETER	TEST CONDITIONS†	TL061Y TL062Y TL064Y			UNIT
		MIN	TYP	MAX	
V_{IO} Input offset voltage	$V_O = 0$, $R_S = 50\ \Omega$		3	15	mV
α_{VIO} Temperature coefficient of input offset voltage	$V_O = 0$, $R_S = 50\ \Omega$		10		$\mu\text{V}/^\circ\text{C}$
I_{IO} Input offset current	$V_O = 0$		5	200	μA
I_{IB} Input bias current‡	$V_O = 0$		30	400	μA
V_{ICR} Common-mode input voltage range		± 11	-12 to 15		V
V_{OM} Maximum peak output voltage swing	$R_L = 10\ \text{k}\Omega$	± 10	± 13.5		V
A_{VD} Large-signal differential voltage amplification	$V_O = \pm 10\ \text{V}$, $R_L \geq 2\ \text{k}\Omega$	3	6		V/mV
B_1 Unity-gain bandwidth	$R_L = 10\ \text{k}\Omega$		1		MHz
r_i Input resistance			10^{12}		Ω
CMRR Common-mode rejection ratio	$V_{IC} = V_{ICR\text{min}}$, $V_O = 0$, $R_S = 50\ \Omega$	70	86		dB
kSVR Supply voltage rejection ratio ($\Delta V_{CC\pm} / \Delta V_{IO}$)	$V_{CC} = \pm 9\ \text{V}$ to $\pm 15\ \text{V}$, $V_O = 0$, $R_S = 50\ \Omega$	70	95		dB
P_D Total power dissipation (each amplifier)	$V_O = 0$, No load		6	7.5	mW
I_{CC} Supply current (per amplifier)	$V_O = 0$, No load		200	250	μA
V_{O1}/V_{O2} Crosstalk attenuation	$A_{VD} = 100$		120		dB

† All characteristics are measured under open-loop conditions with zero common-mode voltage unless otherwise specified.

‡ Input bias currents of a FET-input operational amplifier are normal junction reverse currents, which are temperature sensitive as shown in Figure 15. Pulse techniques must be used that maintain the junction temperature as close to the ambient temperature as possible.

operating characteristics, $V_{CC\pm} = \pm 15\ \text{V}$, $T_A = 25^\circ\text{C}$

PARAMETER	TEST CONDITIONS	TL061Y TL062Y TL064Y			UNIT
		MIN	TYP	MAX	
SR Slew rate at unity gain	$V_I = 10\ \text{mV}$, $R_L = 10\ \text{k}\Omega$, $C_L = 100\ \text{pF}$, See Figure 1	1.5	3.5		V/ μs
t_r Rise time	$V_I = 20\ \text{V}$, $R_L = 10\ \text{k}\Omega$, $C_L = 100\ \text{pF}$, See Figure 1		0.2		μs
Overshoot factor			10%		
V_n Equivalent input noise voltage	$R_S = 20\ \Omega$, $f = 1\ \text{kHz}$		42		$\text{nV}/\sqrt{\text{Hz}}$



PARAMETER MEASUREMENT INFORMATION

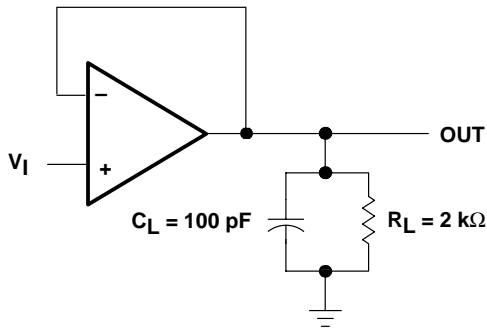

Figure 1. Unity-Gain Amplifier

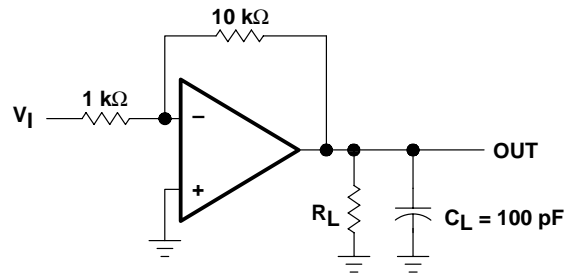

Figure 2. Gain-of-10 Inverting Amplifier

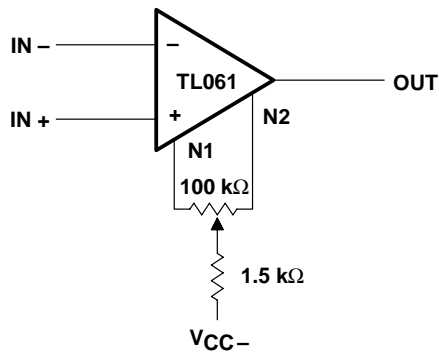

Figure 3. Input Offset Voltage Null Circuit

TYPICAL CHARACTERISTICS

Table of Graphs

		FIGURE		
V _{OM}	Maximum output voltage	vs Supply voltage	4	
		vs Free-air temperature	5	
		vs Load resistance	6	
		vs Frequency	7	
A _{VD}	Differential voltage amplification	vs Free-air temperature	8	
A _{VD}	Large-signal differential voltage amplification	vs Frequency	9	
	Phase shift	vs Frequency	9	
I _{CC}	Supply current	vs Supply voltage	10	
		vs Free-air temperature	11	
P _D	Total power dissipation	vs Free-air temperature	12	
CMRR	Common-mode rejection ratio	vs Free-air temperature	13	
		Normalized unity-gain bandwidth	vs Free-air temperature	14
		Normalized slew rate	vs Free-air temperature	14
		Normalized phase shift	vs Free-air temperature	14
I _{IB}	Input bias current	vs Free-air temperature	15	
		Large-signal pulse response	vs Time	16
V _O	Output voltage	vs Elapsed time	17	
V _n	Equivalent input noise voltage	vs Frequency	18	



TYPICAL CHARACTERISTICS†

MAXIMUM PEAK OUTPUT VOLTAGE
 vs
 SUPPLY VOLTAGE

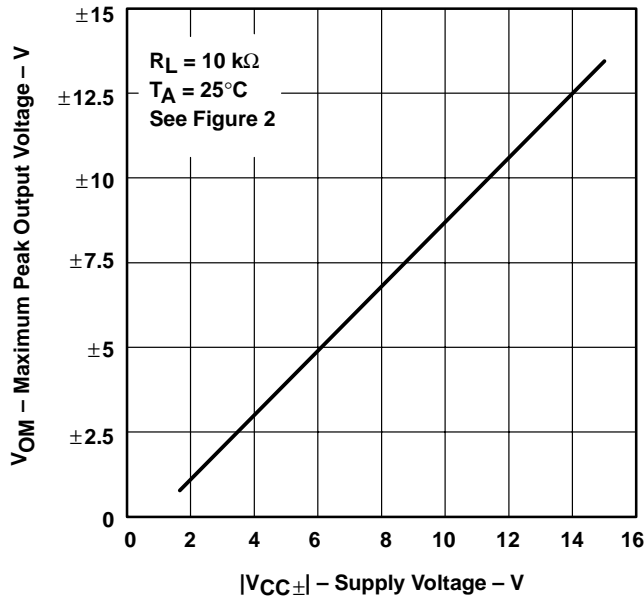

Figure 4

MAXIMUM PEAK OUTPUT VOLTAGE
 vs
 FREE-AIR TEMPERATURE

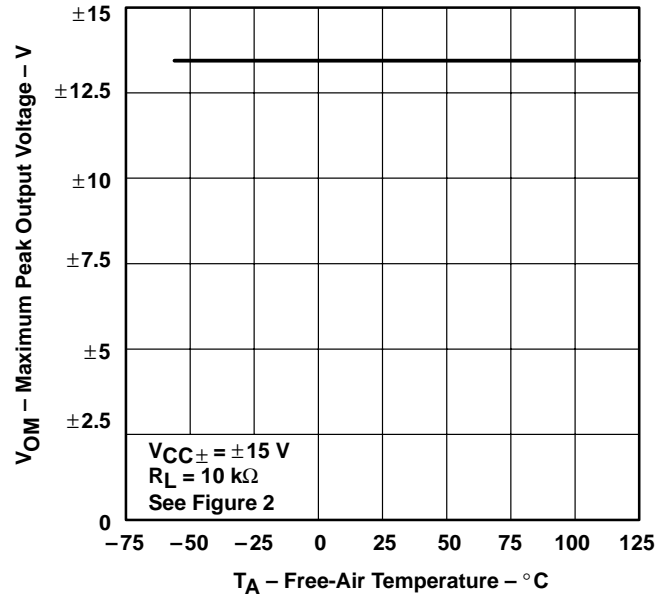

Figure 5

MAXIMUM PEAK OUTPUT VOLTAGE
 vs
 LOAD RESISTANCE

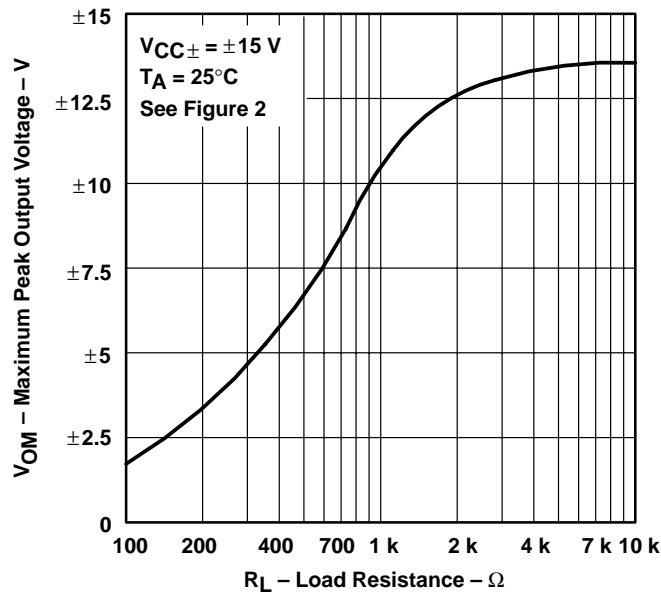

Figure 6

MAXIMUM PEAK OUTPUT VOLTAGE
 vs
 FREQUENCY

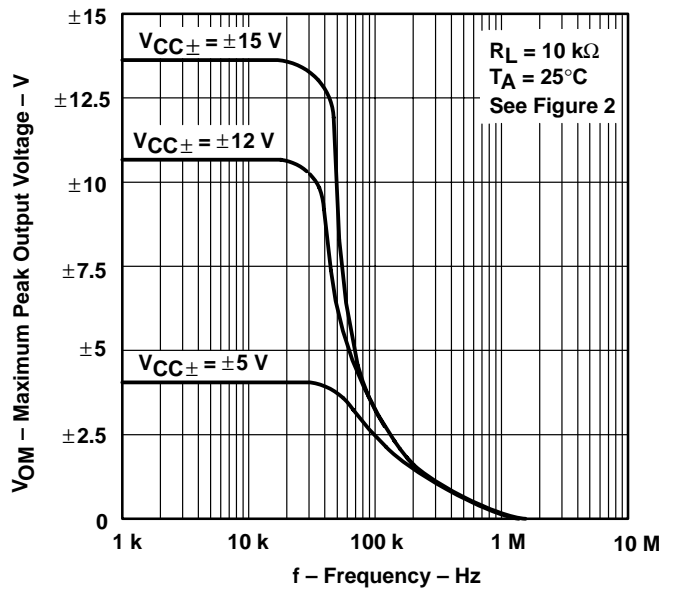

Figure 7

† Data at high and low temperatures are applicable only within the rated operating free-air temperature ranges of the various devices.

TYPICAL CHARACTERISTICS†
 DIFFERENTIAL VOLTAGE AMPLIFICATION
 VS
 FREE-AIR TEMPERATURE

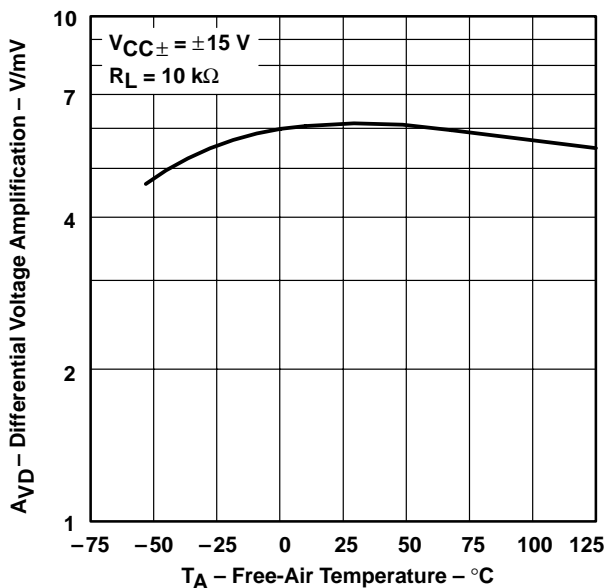

Figure 8

LARGE-SIGNAL
 DIFFERENTIAL VOLTAGE
 AMPLIFICATION AND PHASE SHIFT
 VS
 FREQUENCY

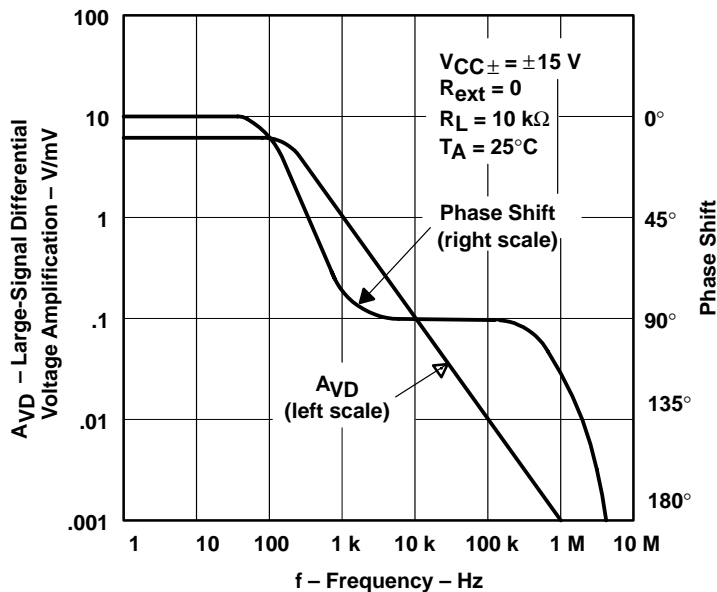

Figure 9

† Data at high and low temperatures are applicable only within the rated operating free-air temperature ranges of the various devices.

TYPICAL CHARACTERISTICS†

SUPPLY CURRENT
 vs
 SUPPLY VOLTAGE

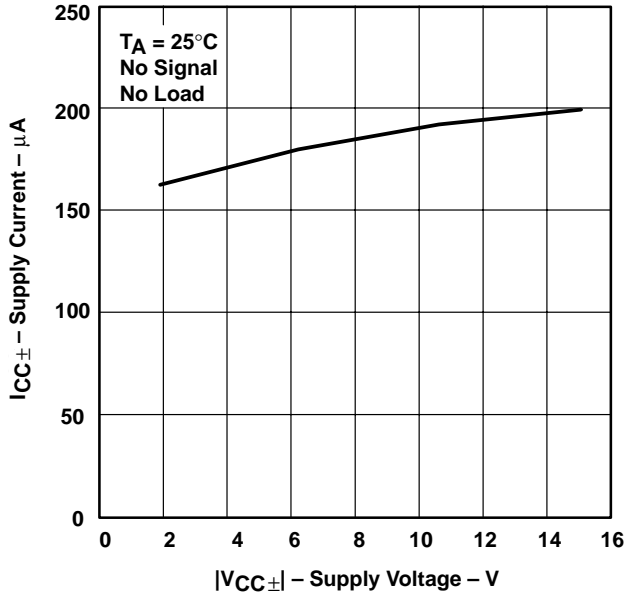

Figure 10

SUPPLY CURRENT
 vs
 FREE-AIR TEMPERATURE

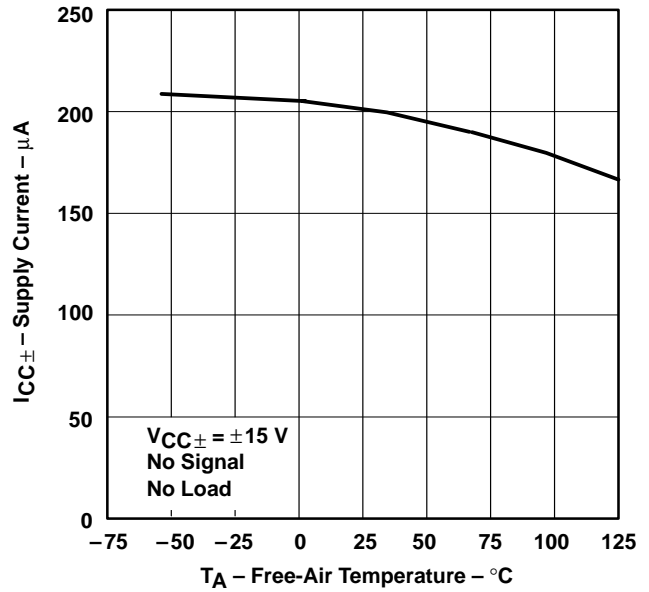

Figure 11

TOTAL POWER DISSIPATION
 vs
 FREE-AIR TEMPERATURE

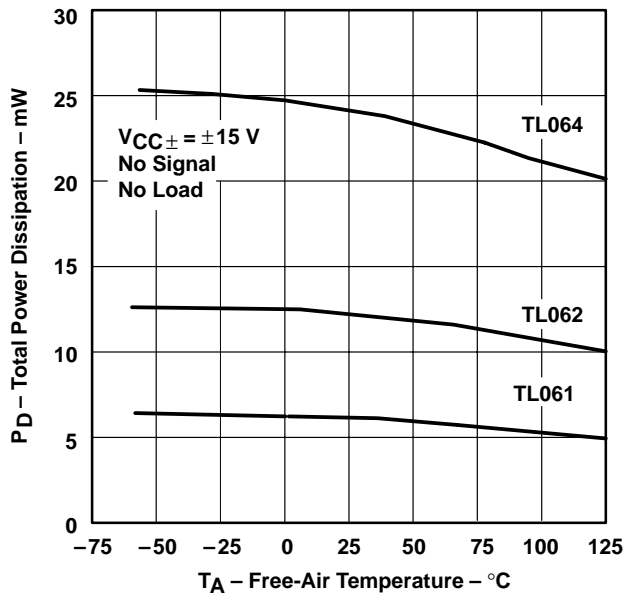

Figure 12

ALL EXCEPT TL06_C
 COMMON-MODE REJECTION RATIO
 vs
 FREE-AIR TEMPERATURE

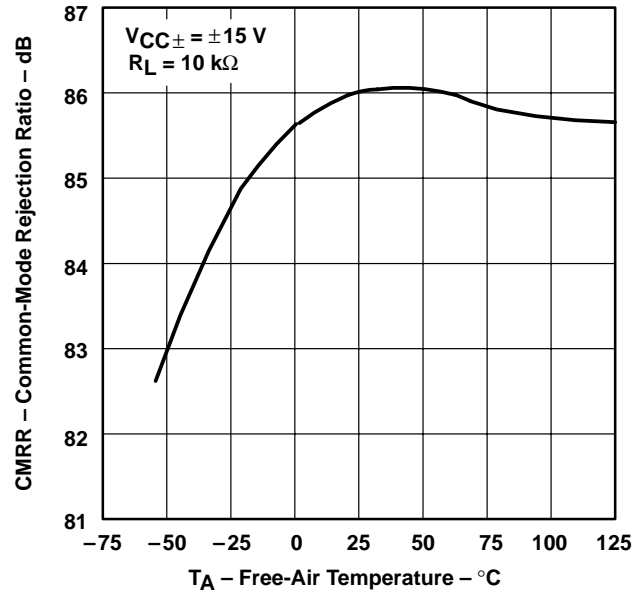

Figure 13

† Data at high and low temperatures are applicable only within the rated operating free-air temperature ranges of the various devices.

TYPICAL CHARACTERISTICS

NORMALIZED UNITY GAIN BANDWIDTH
 SLEW RATE, AND PHASE SHIFT
 vs
 FREE-AIR TEMPERATURE

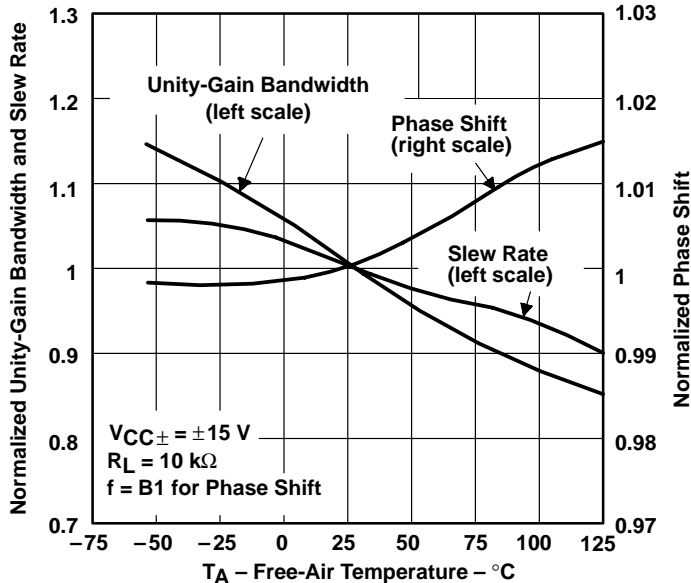

Figure 14

INPUT BIAS CURRENT
 vs
 FREE-AIR TEMPERATURE

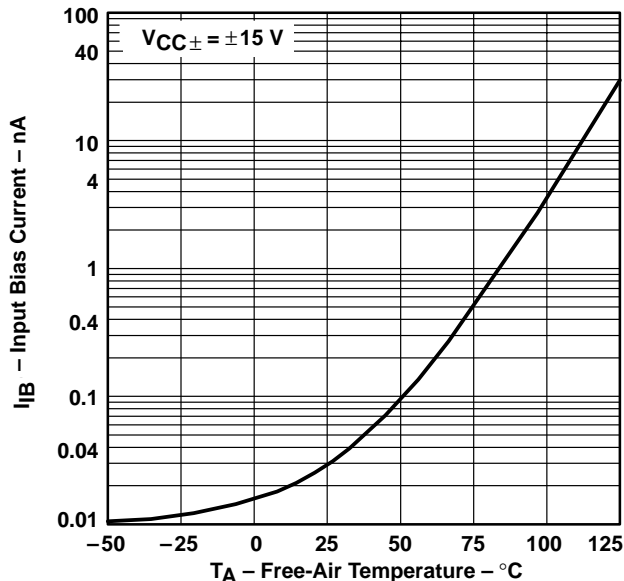

Figure 15

VOLTAGE FOLLOWER
 LARGE SIGNAL PULSE RESPONSE

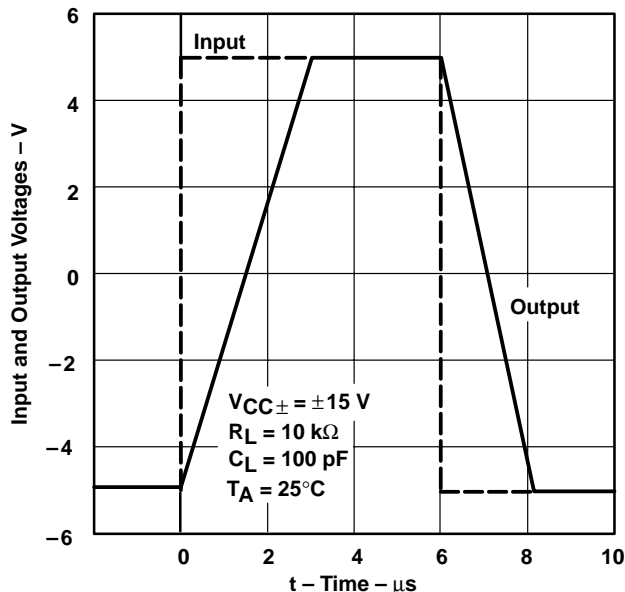
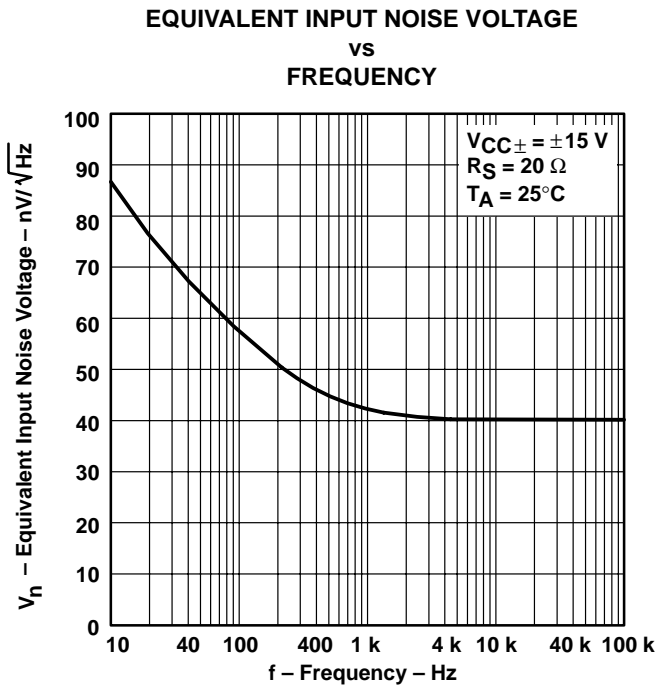
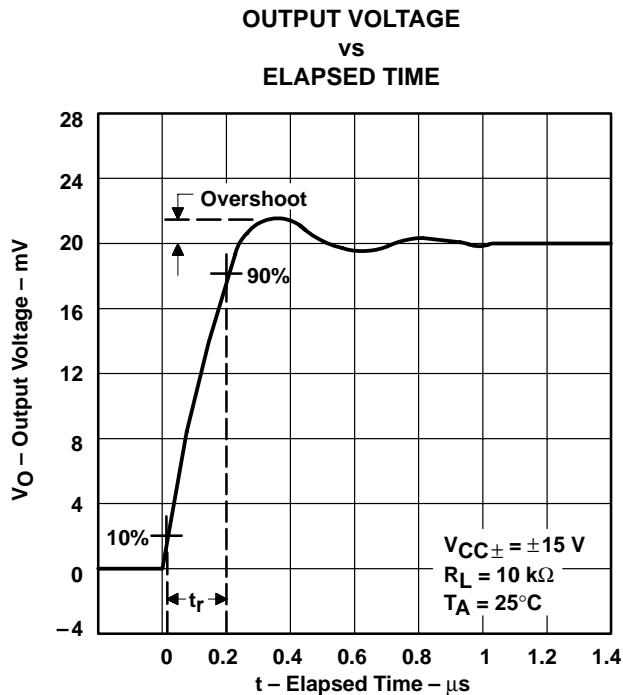

Figure 16

TYPICAL CHARACTERISTICS



APPLICATION INFORMATION

Table of Application Diagrams

APPLICATION DIAGRAM	PART NUMBER	FIGURE
Instrumentation filter	TL064	19
0.5-Hz square-wave oscillator	TL061	20
High-Q notch filter	TL061	21
Audio-distribution amplifier	TL064	22
Low-level light detector preamplifier	TL061	23
AC amplifier	TL061	24
Microphone preamplifier with tone control	TL061	25
Instrumentation amplifier	TL062	26
IC preamplifier	TL062	27

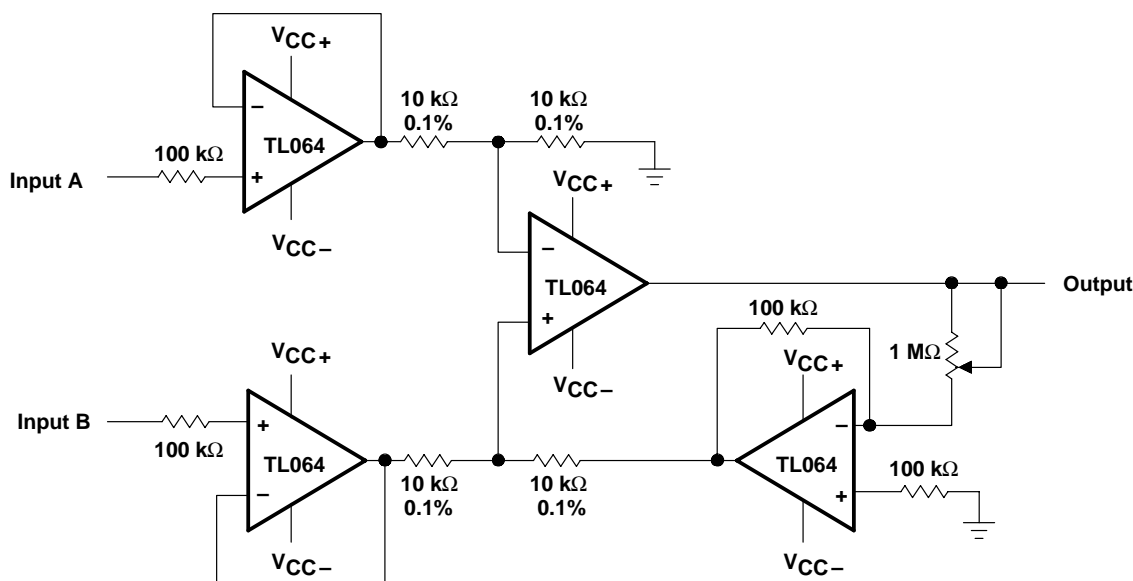

Figure 19. Instrumentation Amplifier

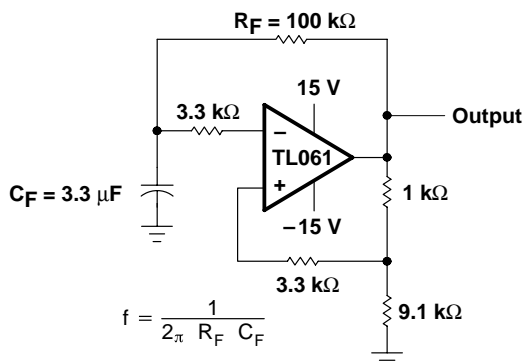

Figure 20. A 0.5-Hz Square-Wave Oscillator

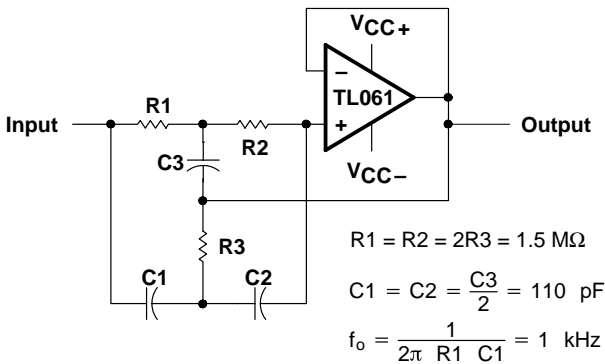

Figure 21. High-Q Notch Filter

APPLICATION INFORMATION

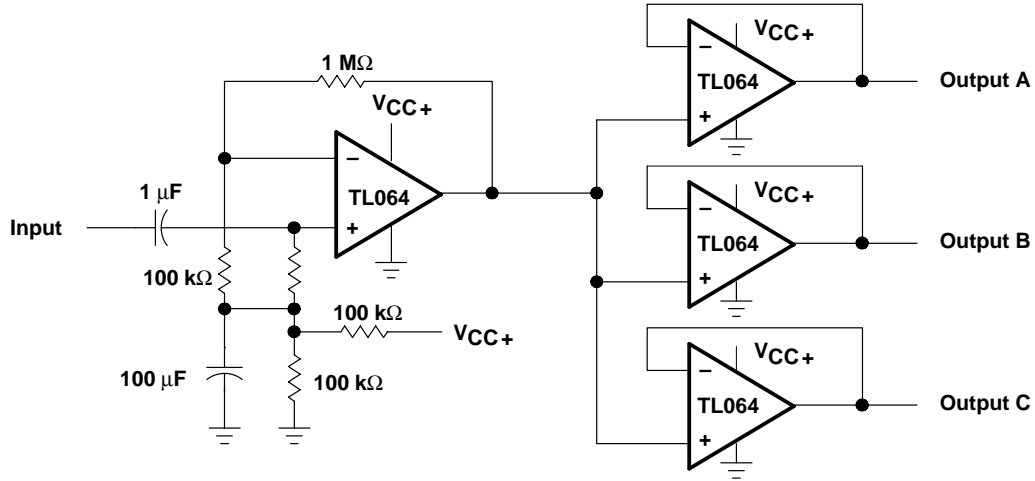

Figure 22. Audio-Distribution Amplifier

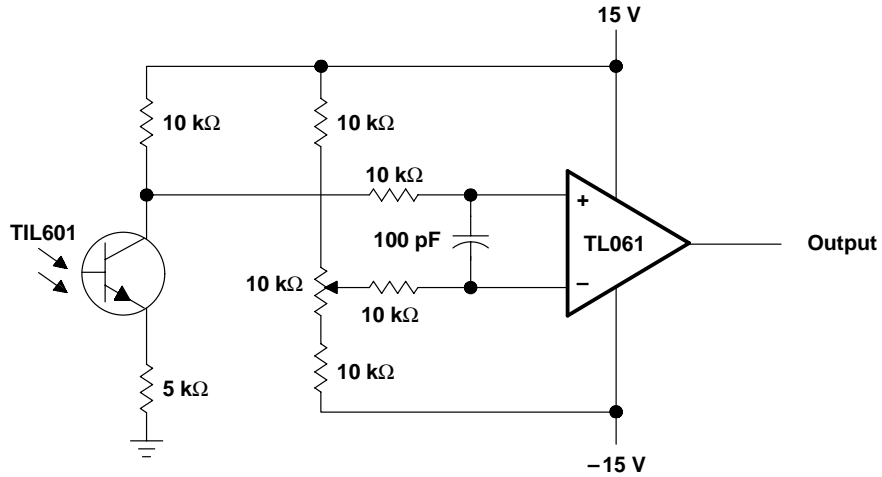

Figure 23. Low-Level Light-Detector Preamplifier

APPLICATION INFORMATION

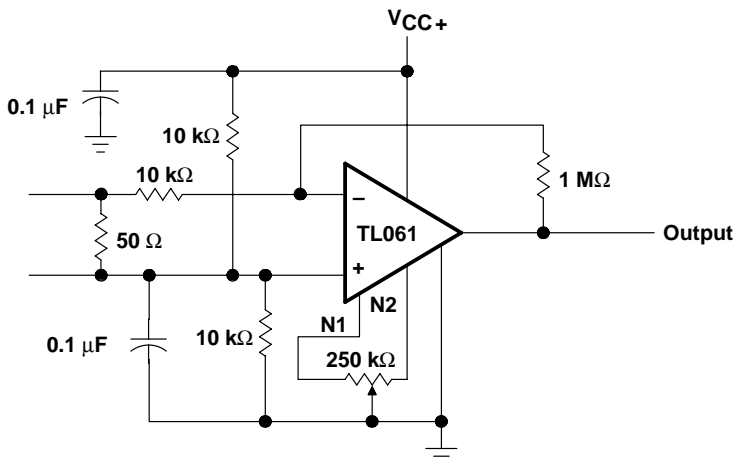

Figure 24. AC Amplifier

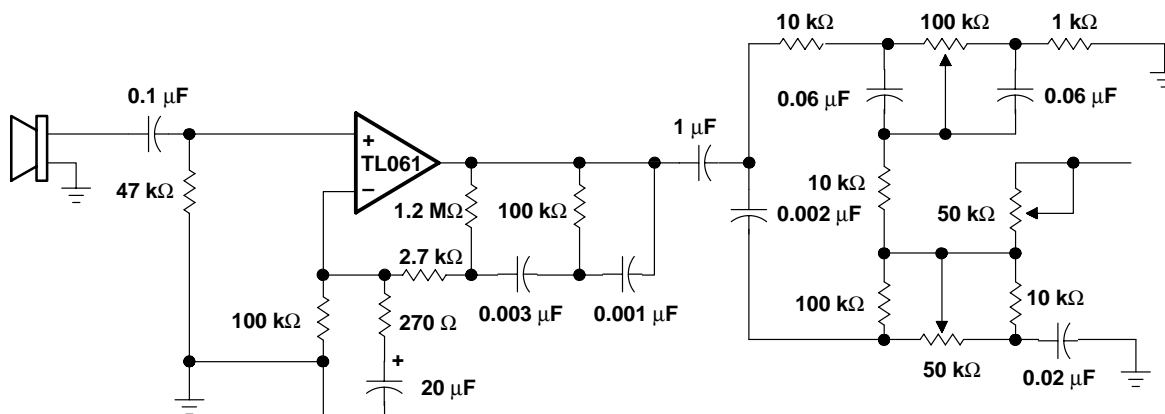

Figure 25. Microphone Preamplifier With Tone Control

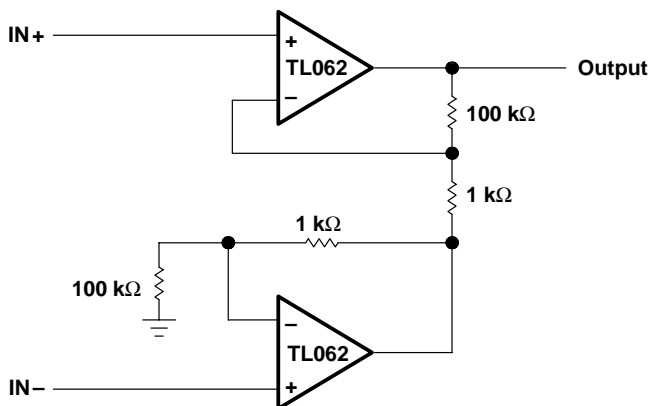

Figure 26. Instrumentation Amplifier

APPLICATION INFORMATION

IC PREAMPLIFIER RESPONSE CHARACTERISTICS

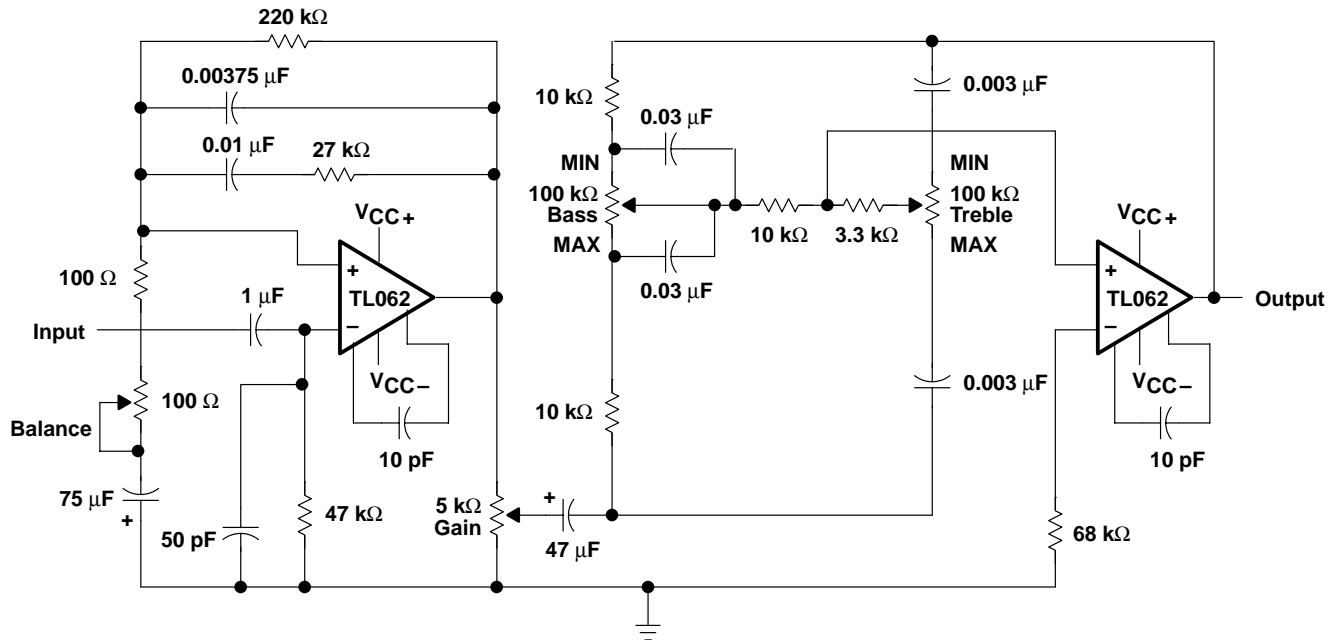
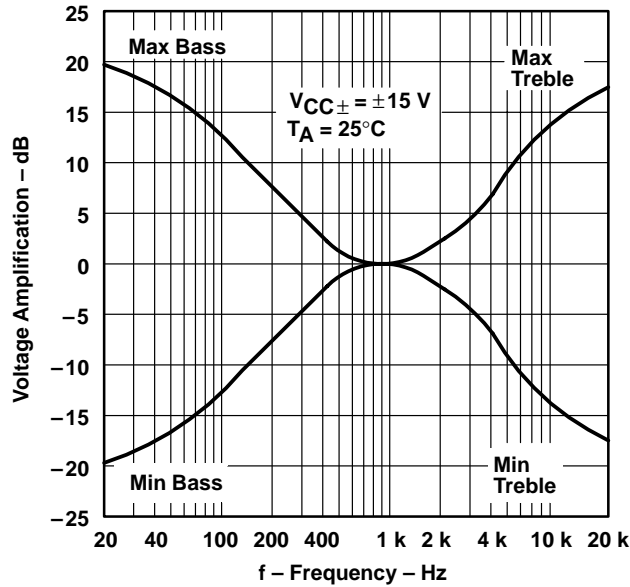

Figure 27. IC Preamplifier

IMPORTANT NOTICE

Texas Instruments (TI) reserves the right to make changes to its products or to discontinue any semiconductor product or service without notice, and advises its customers to obtain the latest version of relevant information to verify, before placing orders, that the information being relied on is current.

TI warrants performance of its semiconductor products and related software to the specifications applicable at the time of sale in accordance with TI's standard warranty. Testing and other quality control techniques are utilized to the extent TI deems necessary to support this warranty. Specific testing of all parameters of each device is not necessarily performed, except those mandated by government requirements.

Certain applications using semiconductor products may involve potential risks of death, personal injury, or severe property or environmental damage ("Critical Applications").

TI SEMICONDUCTOR PRODUCTS ARE NOT DESIGNED, INTENDED, AUTHORIZED, OR WARRANTED TO BE SUITABLE FOR USE IN LIFE-SUPPORT APPLICATIONS, DEVICES OR SYSTEMS OR OTHER CRITICAL APPLICATIONS.

Inclusion of TI products in such applications is understood to be fully at the risk of the customer. Use of TI products in such applications requires the written approval of an appropriate TI officer. Questions concerning potential risk applications should be directed to TI through a local SC sales office.

In order to minimize risks associated with the customer's applications, adequate design and operating safeguards should be provided by the customer to minimize inherent or procedural hazards.

TI assumes no liability for applications assistance, customer product design, software performance, or infringement of patents or services described herein. Nor does TI warrant or represent that any license, either express or implied, is granted under any patent right, copyright, mask work right, or other intellectual property right of TI covering or relating to any combination, machine, or process in which such semiconductor products or services might be or are used.