

DATA SHEET

For a complete data sheet, please also download:

- The IC04 LOCMOS HE4000B Logic Family Specifications HEF, HEC
- The IC04 LOCMOS HE4000B Logic Package Outlines/Information HEF, HEC

HEF4047B

MSI

Monostable/astable multivibrator

Product specification
File under Integrated Circuits, IC04

January 1995

Monostable/astable multivibrator

HEF4047B
MSI

MONOSTABLE/ASTABLE MULTIVIBRATOR

The HEF4047B consists of a gatable astable multivibrator with logic techniques incorporated to permit positive or negative edge-triggered monostable multivibrator action with retriggering and external counting options.

Inputs include + TRIGGER, - TRIGGER, ASTABLE, $\overline{\text{ASTABLE}}$, RETRIGGER and MR (Master Reset). Buffered outputs are O, $\overline{\text{O}}$ and OSCILLATOR OUTPUT. In all modes of operation an external capacitor (C_t) must be connected between C_{TC} and RC_{TC} , and an external resistor (R_t) must be connected between R_{TC} and RC_{TC} (continued on next page).

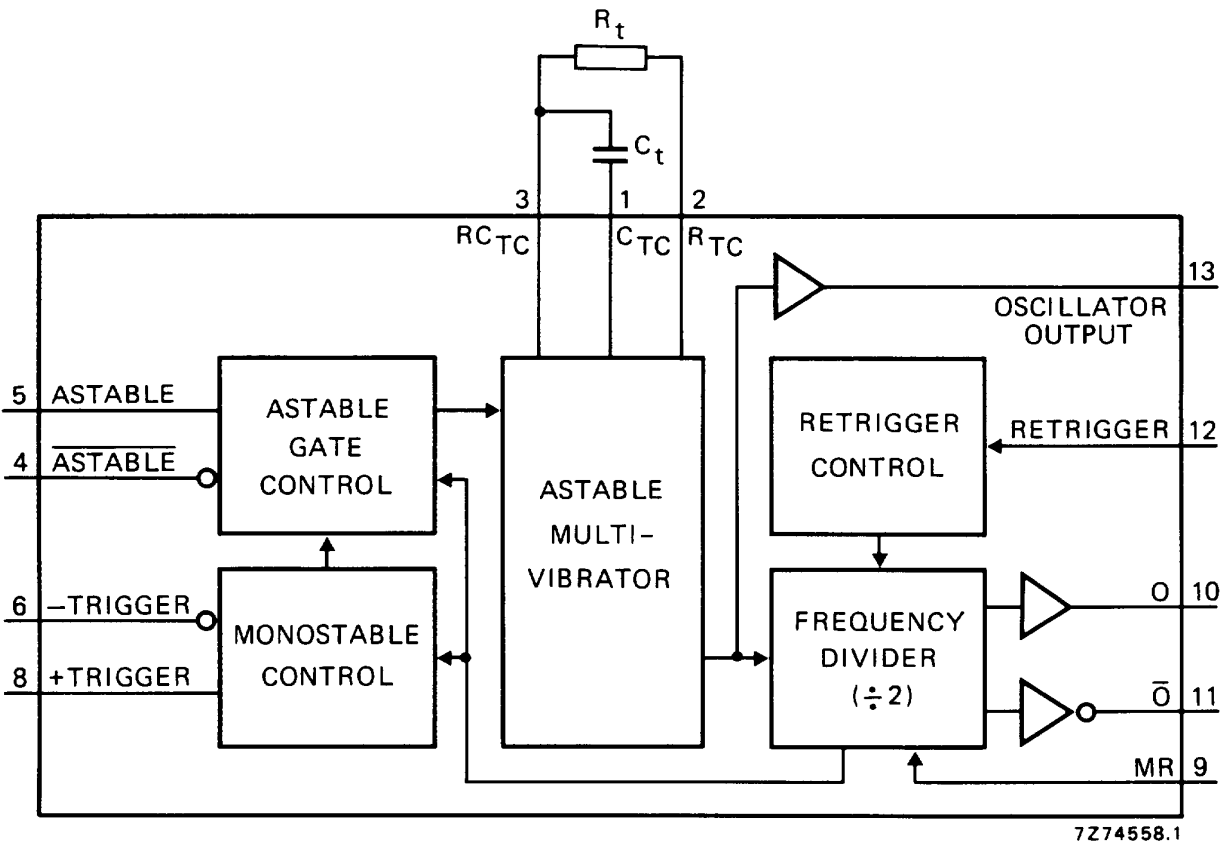

Fig. 1 Functional diagram.

FAMILY DATA

I_{DD} LIMITS category MSI

} see Family Specifications

Monostable/astable multivibrator

HEF4047B
MSI

Astable operation is enabled by a HIGH level on the ASTABLE input. The period of the square wave at O and \bar{O} outputs is a function of the external components employed. 'True' input pulses on the ASTABLE or 'complement' pulses on the ASTABLE input, allow the circuit to be used as a gatable multivibrator. The OSCILLATOR OUTPUT period will be half of the O output in the astable mode. However, a 50% duty factor is not guaranteed at this output.

In the monostable mode, positive edge-triggering is accomplished by applying a leading-edge pulse to the + TRIGGER input and a LOW level to the - TRIGGER input. For negative edge-triggering, a trailing-edge pulse is applied to the - TRIGGER and a HIGH level to the + TRIGGER. Input pulses may be of any duration relative to the output pulse. The multivibrator can be retriggered (on the leading-edge only) by applying a common pulse to both the RETRIGGER and + TRIGGER inputs. In this mode the output pulse remains HIGH as long as the input pulse period is shorter than the period determined by the RC components.

An external count down option can be implemented by coupling O to an external 'N' counter and resetting the counter with the trigger pulse. The counter output pulse is fed back to the ASTABLE input and has a duration equal to N times the period of the multivibrator. A HIGH level on the MR input assures no output pulse during an ON-power condition. This input can also be activated to terminate the output pulse at any time. In the monostable mode, a HIGH level or power-ON reset pulse must be applied to MR, whenever V_{DD} is applied.

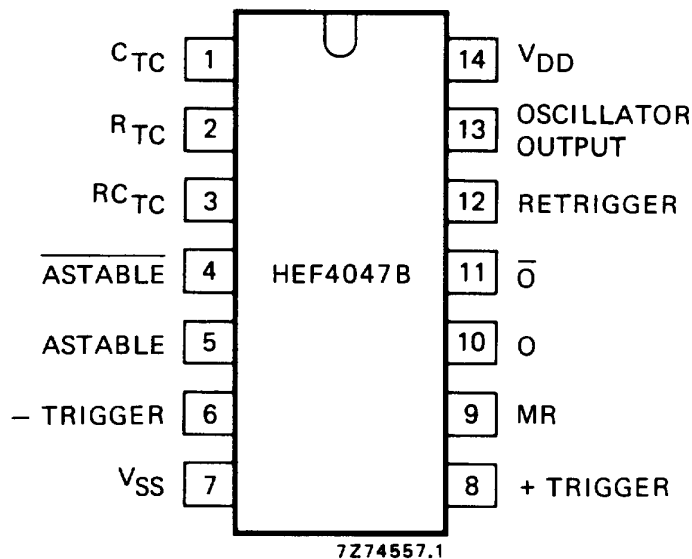

Fig. 2 Pinning diagram.

HEF4047BP(N): 14-lead DIL; plastic
(SOT27-1)

HEF4047BD(F): 14-lead DIL; ceramic (cerdip)
(SOT73)

HEF4047BT(D): 14-lead SO; plastic
(SOT108-1)

(): Package Designator North America

Monostable/astable multivibrator

HEF4047B
MSI

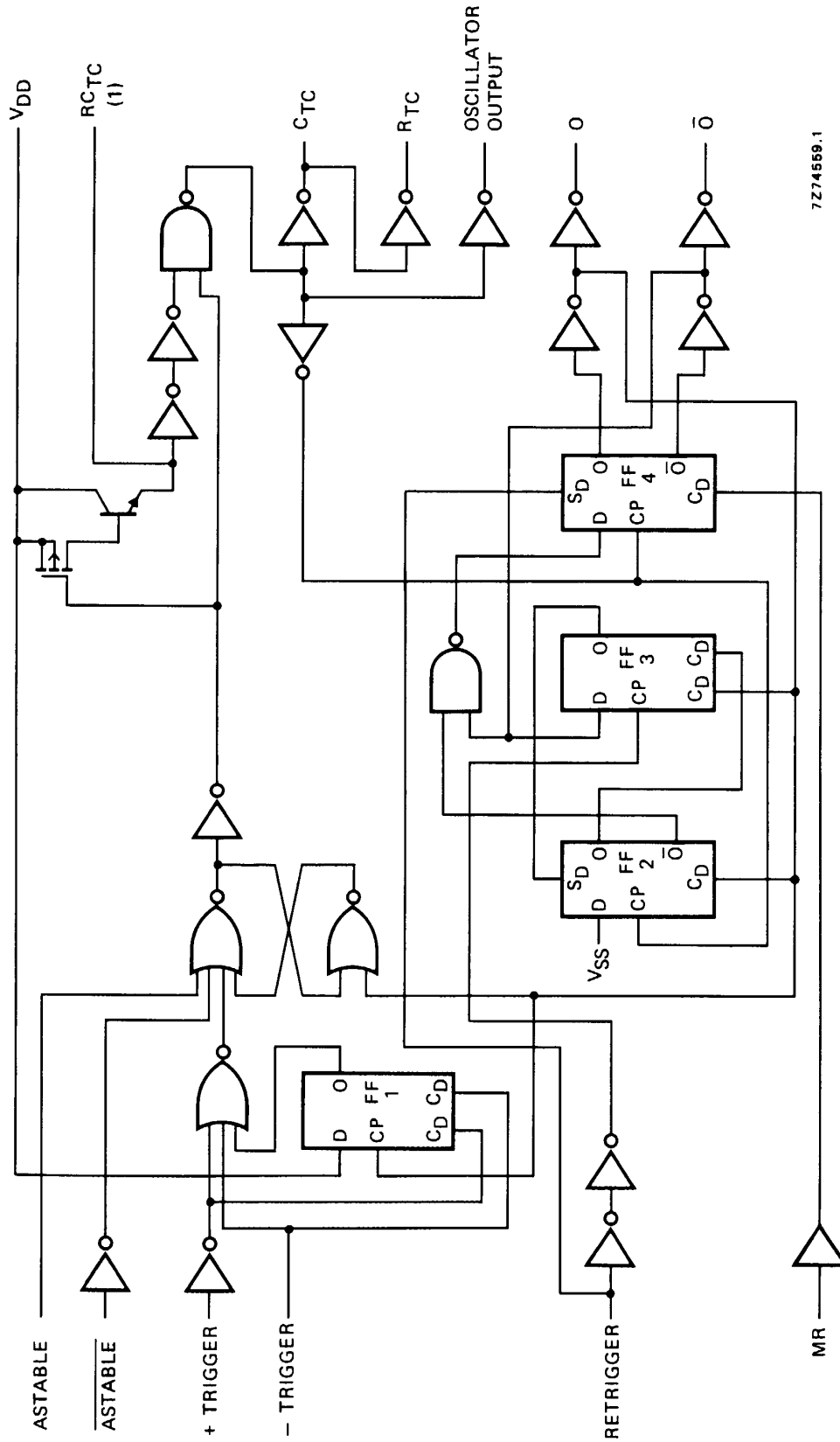

(1) Special input protection that allows operating input voltages outside the supply voltage lines. Compared to the standard input protection pin 3 is more sensitive to static discharge; extra handling precautions are recommended.

Fig. 3 Logic diagram.

Monostable/astable multivibrator

HEF4047B
MSI

FUNCTIONAL CONNECTIONS

function	pins connected to			output pulse from pins	output period or pulse width
	V _{DD}	V _{SS}	input pulse		
astable multivibrator					
free running	4, 5, 6, 14	7, 8, 9, 12	—	10, 11, 13	at pins 10, 11: $t_A = 4,40 R_t C_t$
true gating	4, 6, 14	7, 8, 9, 12	5	10, 11, 13	at pin 13: $t_A = 2,20 R_t C_t$
complement gating	6, 14	5, 7, 8, 9, 12	4	10, 11, 13	
monostable multivibrator					
pos. edge-triggering	4, 14	5, 6, 7, 9, 12	8	10, 11	at pins 10, 11: $t_M = 2,48 R_t C_t$
neg. edge-triggering	4, 8, 14	5, 7, 9, 12	6	10, 11	
retriggerable	4, 14	5, 6, 7, 9	8, 12	10, 11	
external count down*	14	5, 6, 7, 8, 9, 12	—	10, 11	

* Input pulse to RESET of external counting chip; external counting chip output to pin 4.

Note

In all cases, external resistor between pins 2 and 3, external capacitor between pins 1 and 3.

D.C. CHARACTERISTICS

V_{SS} = 0 V; inputs at V_{SS} or V_{DD}

	V _{DD} V	symbol	T _{amb} (°C)				
			−40 max.	+25 min.	+85 max.	+85 max.	
Leakage current pin 3; output transistor OFF	15	I ₃	0,3	—	0,3	1 μA	pin 3 at V _{DD} or V _{SS}

Monostable/astable multivibrator

HEF4047B
MSI

A.C. CHARACTERISTICS

 $V_{SS} = 0\text{ V}$; $T_{amb} = 25\text{ }^{\circ}\text{C}$; $C_L = 50\text{ pF}$; input transition times $\leq 20\text{ ns}$

	V_{DD} V	symbol	min. typ. max.	typical extrapolation formula
Propagation delays				
<u>ASTABLE, ASTABLE</u>				
\rightarrow OSC. OUTPUT	5		95 190	$68\text{ ns} + (0,55\text{ ns/pF}) C_L$
HIGH to LOW	10	t_{PHL}	45 90	$43\text{ ns} + (0,23\text{ ns/pF}) C_L$
	15		30 60	$22\text{ ns} + (0,16\text{ ns/pF}) C_L$
LOW to HIGH	5		85 170	$58\text{ ns} + (0,55\text{ ns/pF}) C_L$
	10	t_{PLH}	40 80	$29\text{ ns} + (0,23\text{ ns/pF}) C_L$
	15		30 60	$22\text{ ns} + (0,16\text{ ns/pF}) C_L$
<u>ASTABLE, ASTABLE</u>				
\rightarrow O, \bar{O}	5		150 300	$123\text{ ns} + (0,55\text{ ns/pF}) C_L$
HIGH to LOW	10	t_{PHL}	65 130	$54\text{ ns} + (0,23\text{ ns/pF}) C_L$
	15		50 100	$42\text{ ns} + (0,16\text{ ns/pF}) C_L$
LOW to HIGH	5		130 260	$103\text{ ns} + (0,55\text{ ns/pF}) C_L$
	10	t_{PLH}	60 120	$49\text{ ns} + (0,23\text{ ns/pF}) C_L$
	15		45 90	$37\text{ ns} + (0,16\text{ ns/pF}) C_L$
<u>+/- TRIGGER</u>				
\rightarrow O, \bar{O}	5		160 320	$133\text{ ns} + (0,55\text{ ns/pF}) C_L$
HIGH to LOW	10	t_{PHL}	65 130	$54\text{ ns} + (0,23\text{ ns/pF}) C_L$
	15		50 100	$42\text{ ns} + (0,16\text{ ns/pF}) C_L$
LOW to HIGH	5		155 310	$128\text{ ns} + (0,55\text{ ns/pF}) C_L$
	10	t_{PLH}	65 130	$54\text{ ns} + (0,23\text{ ns/pF}) C_L$
	15		50 100	$42\text{ ns} + (0,16\text{ ns/pF}) C_L$
<u>+ TRIGGER, RETRIGGER $\rightarrow \bar{O}$</u>				
HIGH to LOW	5		65 130	$38\text{ ns} + (0,55\text{ ns/pF}) C_L$
	10	t_{PHL}	30 60	$19\text{ ns} + (0,23\text{ ns/pF}) C_L$
	15		25 50	$17\text{ ns} + (0,16\text{ ns/pF}) C_L$
<u>+ TRIGGER, RETRIGGER $\rightarrow O$</u>				
LOW to HIGH	5		95 190	$68\text{ ns} + (0,55\text{ ns/pF}) C_L$
	10	t_{PLH}	40 80	$29\text{ ns} + (0,23\text{ ns/pF}) C_L$
	15		30 60	$22\text{ ns} + (0,16\text{ ns/pF}) C_L$
<u>MR $\rightarrow O$</u>				
HIGH to LOW	5		100 200	$83\text{ ns} + (0,55\text{ ns/pF}) C_L$
	10	t_{PHL}	45 90	$34\text{ ns} + (0,23\text{ ns/pF}) C_L$
	15		35 70	$27\text{ ns} + (0,16\text{ ns/pF}) C_L$
<u>MR $\rightarrow \bar{O}$</u>				
LOW to HIGH	5		100 200	$83\text{ ns} + (0,55\text{ ns/pF}) C_L$
	10	t_{PLH}	45 90	$34\text{ ns} + (0,23\text{ ns/pF}) C_L$
	15		35 70	$27\text{ ns} + (0,16\text{ ns/pF}) C_L$

Monostable/astable multivibrator

HEF4047B
MSI**A.C. CHARACTERISTICS** (continued) $V_{SS} = 0\text{ V}$; $T_{amb} = 25\text{ }^{\circ}\text{C}$; $C_L = 50\text{ pF}$; input transition times $\leq 20\text{ ns}$

	V_{DD} V	symbol	min.	typ.	max.	typical extrapolation formula	
Output transition times HIGH to LOW	5	t_{THL}		60	120	ns	$10\text{ ns} + (1,0\text{ ns/pF}) C_L$
	10		30	60	ns	$9\text{ ns} + (0,42\text{ ns/pF}) C_L$	
	15		20	40	ns	$6\text{ ns} + (0,28\text{ ns/pF}) C_L$	
LOW to HIGH	5	t_{TLH}		60	120	ns	$10\text{ ns} + (1,0\text{ ns/pF}) C_L$
	10		30	60	ns	$9\text{ ns} + (0,42\text{ ns/pF}) C_L$	
	15		20	40	ns	$6\text{ ns} + (0,28\text{ ns/pF}) C_L$	
Minimum MR pulse width; HIGH	5	t_{WMRH}	60	30		ns	
	10		30	15		ns	
	15		20	10		ns	
Minimum input pulse width; any input except MR	5	t_W	220	110		ns	
	10		100	50		ns	
	15		70	35		ns	

APPLICATION INFORMATION**General features:**

- Monostable (one-shot) or astable (free-running) operation
- True and complemented buffered outputs
- Only one external R and C required

Monostable multivibrator features:

- Positive- or negative-edge triggering
- Output pulse width independent of trigger pulse duration
- Retriggerable option for pulse-width expansion
- Long pulse width possible using small RC components by means of external counter provision
- Fast recovery time essentially independent of pulse width
- Pulse-width accuracy maintained at duty cycles approaching 100%

Astable multivibrator features:

- Free-running or gatable operating modes
- 50% duty cycle
- Oscillator output available

Monostable/astable multivibrator

HEF4047B
MSI

1. Astable mode design information

a. Unit-to-unit transfer-voltage variations

The following analysis presents worst-case variations from unit-to-unit as a function of transfer-voltage (V_{TR}) shift for free running (astable) operation.

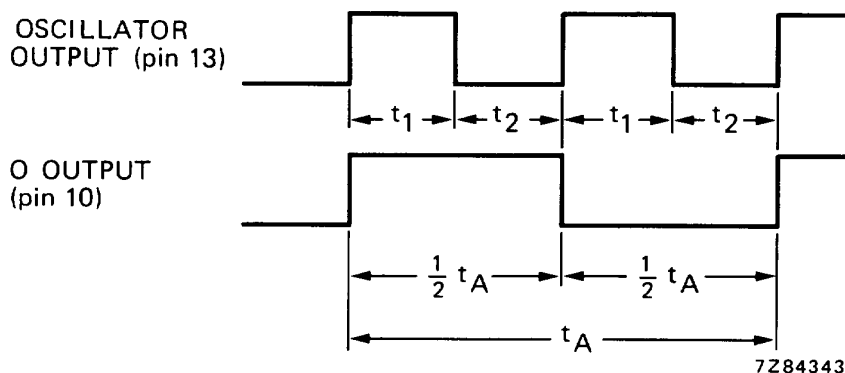

Fig. 4 Astable mode waveforms.

$$t_1 = -R_t C_t \ln \frac{V_{TR}}{V_{DD} + V_{TR}}$$

$$t_2 = -R_t C_t \ln \frac{V_{DD} - V_{TR}}{2V_{DD} - V_{TR}}$$

$$t_A = 2(t_1 + t_2) = -2R_t C_t \ln \frac{(V_{TR})(V_{DD} - V_{TR})}{(V_{DD} + V_{TR})(2V_{DD} - V_{TR})}$$
 , where t_A = Astable mode pulse width.

Values for t_A are:

	typ. : $V_{TR} = 0,5 V_{DD}$; $t_A = 4,40 R_t C_t$
$V_{DD} = 5 \text{ or } 10 \text{ V}$	{ min. : $V_{TR} = 0,3 V_{DD}$; $t_A = 4,71 R_t C_t$
	{ max. : $V_{TR} = 0,7 V_{DD}$; $t_A = 4,71 R_t C_t$
$V_{DD} = 15 \text{ V}$	{ min. : $V_{TR} = 4 \text{ V}$; $t_A = 4,84 R_t C_t$
	{ max. : $V_{TR} = 11 \text{ V}$; $t_A = 4,84 R_t C_t$

thus if $t_A = 4,40 R_t C_t$ is used, the maximum variation will be (+ 7,0%; -0,0%) at 10 V.

Monostable/astable multivibrator

HEF4047B
MSI**APPLICATION INFORMATION** (continued)*b. Variations due to changes in V_{DD}*

In addition to variations from unit-to-unit, the astable period may vary as a function of frequency with respect to V_{DD} .

Typical variations are presented graphically in Figs 5 and 6 with 10 V as a reference.

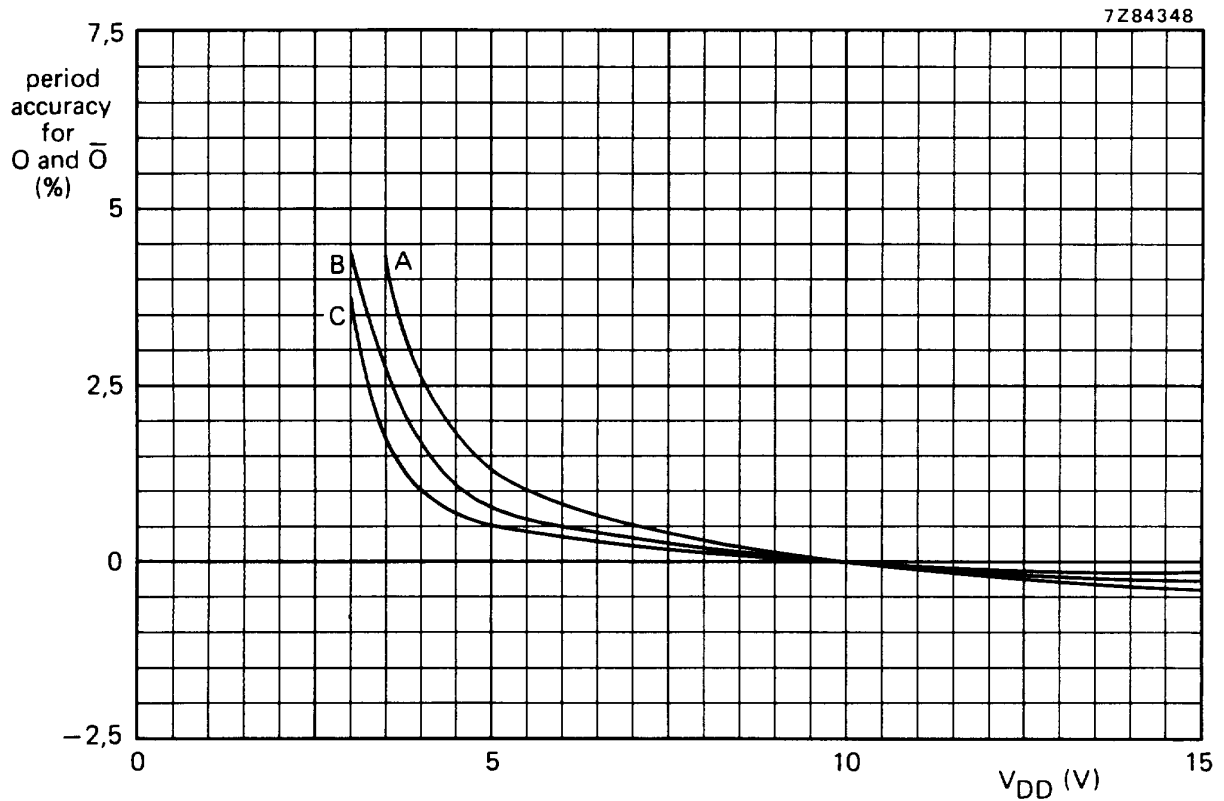

Fig. 5 Typical O and \bar{O} period accuracy as a function of supply voltage; astable mode; $T_{amb} = 25\text{ }^{\circ}\text{C}$.

curve	f_o kHz	C_t pF	R_t k Ω
A	10	100	220
B	5	100	470
C	1	1000	220

Monostable/astable multivibrator

HEF4047B
MSI

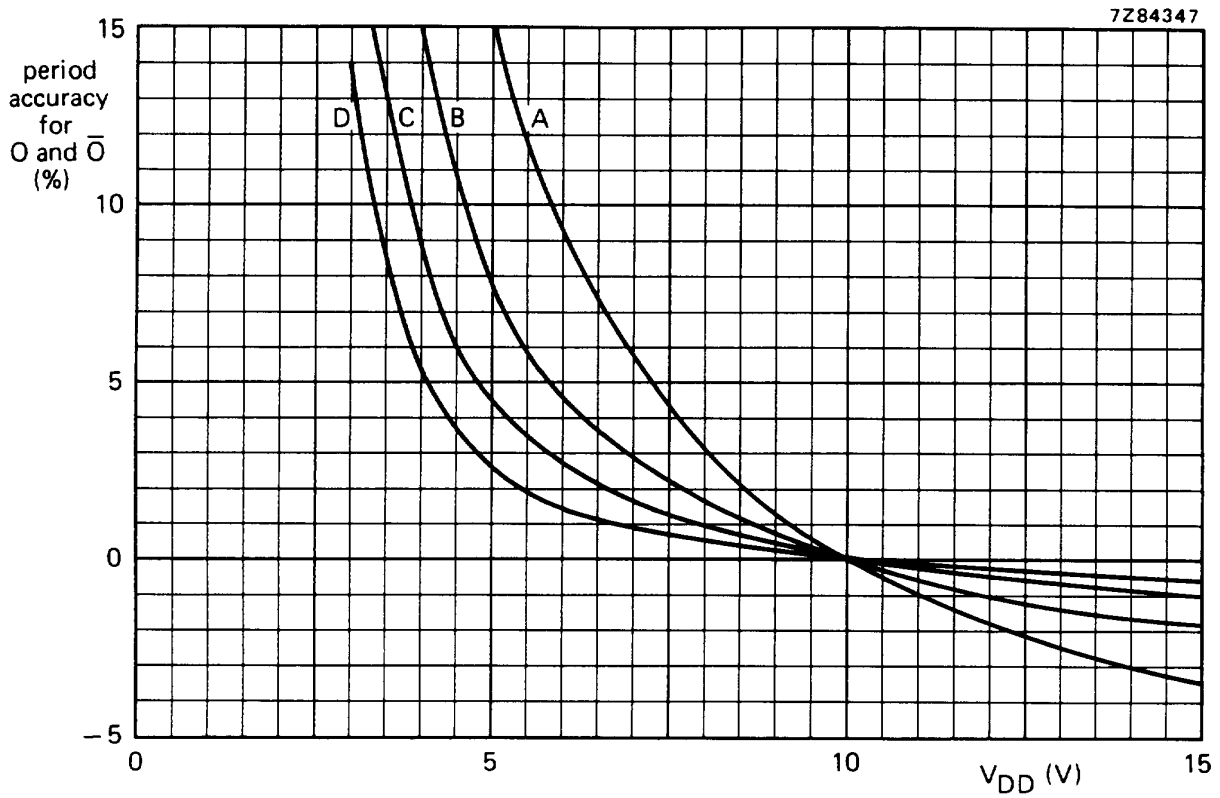

Fig. 6 Typical O and \bar{O} period accuracy as a function of supply voltage; astable mode; $T_{amb} = 25\text{ }^{\circ}\text{C}$.

curve	f_o kHz	C_t pF	R_t k Ω
A	500	10	47
B	225	100	10
C	100	100	22
D	50	100	47

Monostable/astable multivibrator

HEF4047B
MSI

APPLICATION INFORMATION (continued)

2. Monostable mode design information

The following analysis presents worst case variations from unit-to-unit as a function of transfer-voltage (V_{TR}) shift for one-shot (monostable) operation.

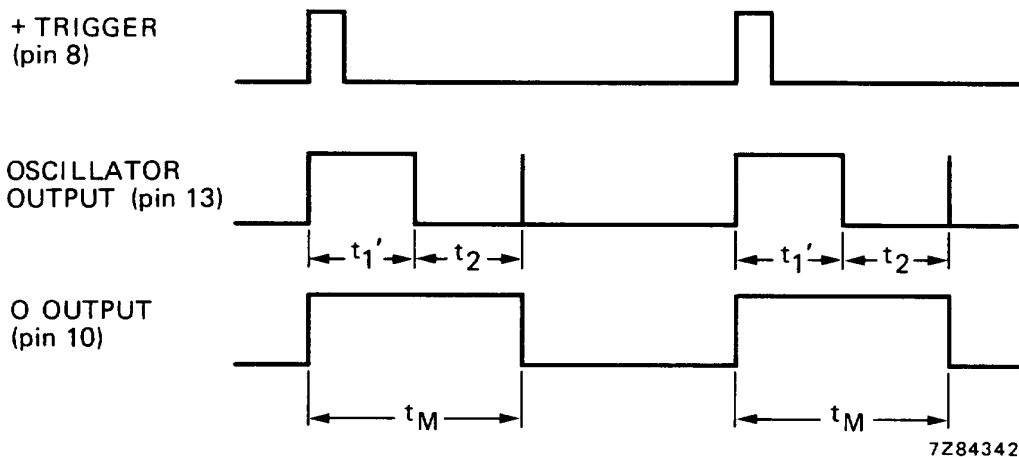

Fig. 7 Monostable waveforms.

$$t_1' = -R_t C_t \ln \frac{V_{TR}}{2V_{DD}}$$

$$t_M = (t_1' + t_2)$$

$$t_M = -R_t C_t \ln \frac{(V_{TR})(V_{DD} - V_{TR})}{(2V_{DD} - V_{TR})(2V_{DD})}, \text{ where } t_M = \text{Monostable mode pulse width.}$$

Values for t_M are:

	typ. : $V_{TR} = 0,5 V_{DD}$; $t_M = 2,48 R_t C_t$
$V_{DD} = 5 \text{ to } 10 \text{ V}$	{ min. : $V_{TR} = 0,3 V_{DD}$; $t_M = 2,78 R_t C_t$
	{ max. : $V_{TR} = 0,7 V_{DD}$; $t_M = 2,52 R_t C_t$
$V_{DD} = 15 \text{ V}$	{ min. : $V_{TR} = 4 \text{ V}$; $t_M = 2,88 R_t C_t$
	{ max. : $V_{TR} = 11 \text{ V}$; $t_M = 2,56 R_t C_t$

thus if $t_M = 2,48 R_t C_t$ is used, the maximum variation will be (+ 12%; -0,0%) at 10 V.

Note

In the astable mode, the first positive half cycle has a duration of t_M ; succeeding durations are $\frac{1}{2} t_A$.

Monostable/astable multivibrator

HEF4047B
MSI

3. Retrigger mode operation

The HEF4047B can be used in the retrigger mode to extend the output pulse duration, or to compare the frequency of an input signal with that of the internal oscillator. In the retrigger mode the input pulse is applied to pins 8 and 12, and the output is taken from pin 10 or 11. Normal monostable action is obtained when one retrigger pulse is applied (Fig. 8).

Extended pulse duration is obtained when more than one pulse is applied. For two input pulses, $t_{RE} = t_1' + t_1 + 2t_2$.

For more than two pulses, t_{RE} (output O), terminates at some variable time, t_D , after the termination of the last retrigger pulse; t_D is variable because t_{RE} (output O) terminates after the second positive edge of the oscillator output appears at flip-flop 4.

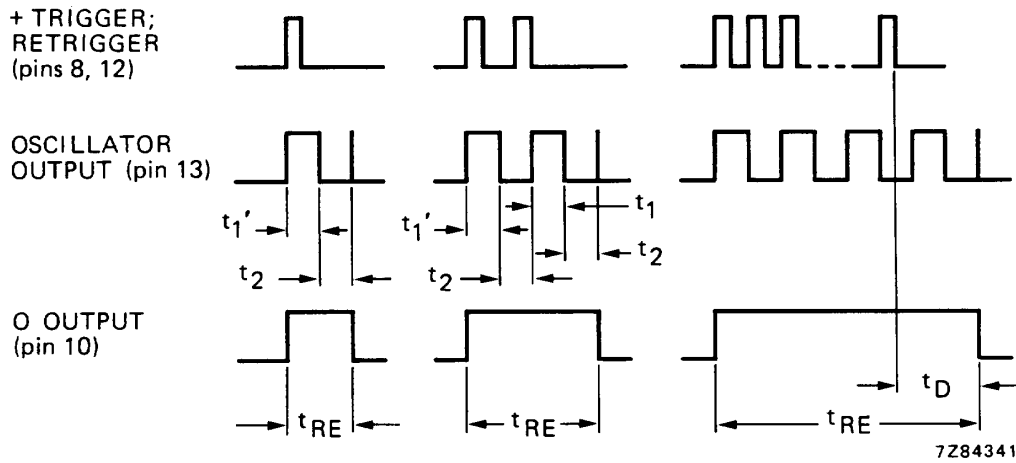

Fig. 8 Retrigger mode waveforms.

4. External counter option

Time t_M can be extended by any amount with the use of external counting circuitry. Advantages include digitally controlled pulse duration, small timing capacitors for long time periods, and extremely fast recovery time. A typical implementation is shown in Fig. 9.

The pulse duration at the output is:

$$t_{ext} = (N - 1)(t_A) + (t_M + \frac{1}{2} t_A)$$

Where t_{ext} = pulse duration of the circuitry, and N is the number of counts used.

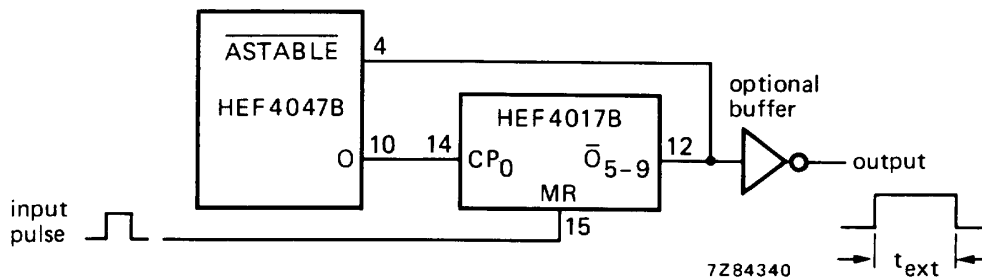

Fig. 9 Implementation of external counter option.

Monostable/astable multivibrator

HEF4047B
MSI**APPLICATION INFORMATION** (continued)**5. Timing component limitations**

The capacitor used in the circuit should be non-polarized and have low leakage (i.e. the parallel resistance of the capacitor should be an order of magnitude greater than the external resistor used). There is no upper or lower limit for either R_t or C_t value to maintain oscillation.

However, in consideration of accuracy, C_t must be much larger than the inherent stray capacitance in the system (unless this capacitance can be measured and taken into account).

R_t must be much larger than the LOCMOS 'ON' resistance in series with it, which typically is hundreds of ohms.

The recommended values for R_t and C_t to maintain agreement with previously calculated formulae without trimming should be:

$$C_t \geq 100 \text{ pF, up to any practical value,}$$

$$10 \text{ k}\Omega \leq R_t \leq 1 \text{ M}\Omega.$$

6. Power consumption

In the standby mode (monostable or astable), power dissipation will be a function of leakage current in the circuit.

For dynamic operation, the power needed to charge the external timing capacitor C_t is given by the following formulae:

Astable mode: $P = 2 C_t V^2 f$ (f at output pin 13)

$$P = 4 C_t V^2 f \text{ (f at output pins 10 and 11)}$$

Monostable mode: $P = \frac{(2,9 C_t V^2)(\text{duty cycle})}{T}$ (f at output pins 10 and 11)

Because the power dissipation does not depend on R_t , a design for minimum power dissipation would be a small value of C_t . The value of R would depend on the desired period (within the limitations discussed previously).

Typical power consumption in astable mode is shown in Figs 10, 11 and 12.

Monostable/astable multivibrator

HEF4047B
MSI

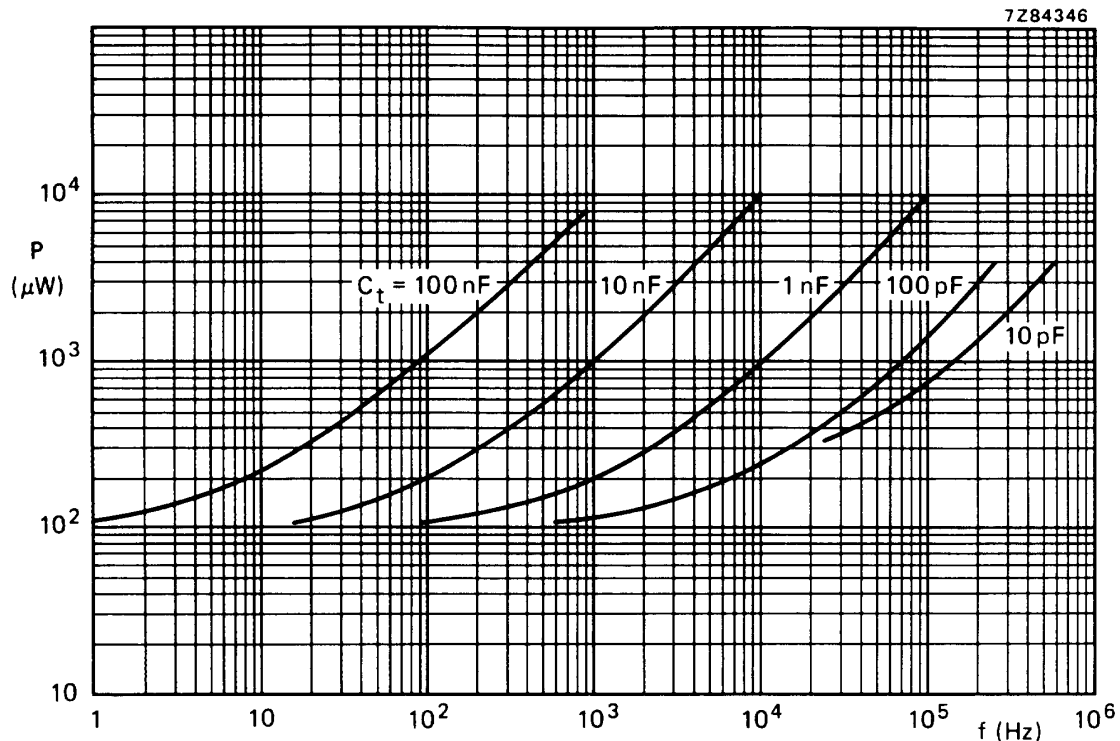

Fig. 10 Power consumption as a function of the output frequency at O or \bar{O} ; $V_{DD} = 5\text{ V}$; astable mode.

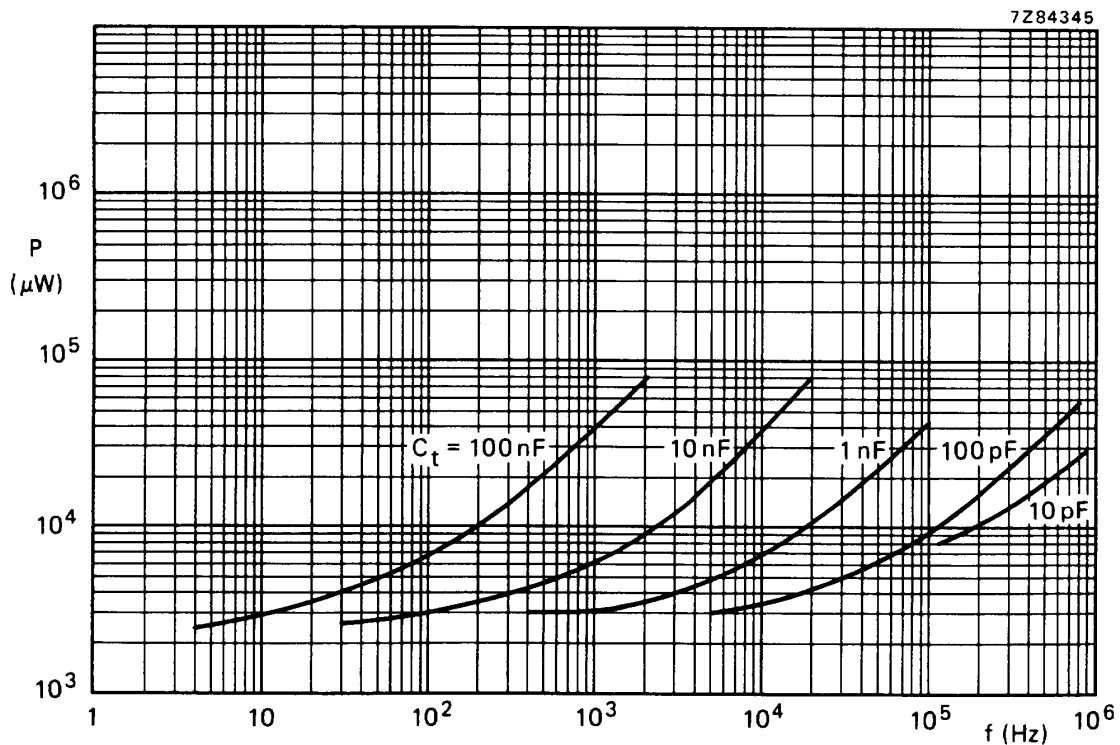

Fig. 11 Power consumption as a function of the output frequency at O or \bar{O} ; $V_{DD} = 10\text{ V}$; astable mode.

Monostable/astable multivibrator

HEF4047B
MSI

APPLICATION INFORMATION (continued)

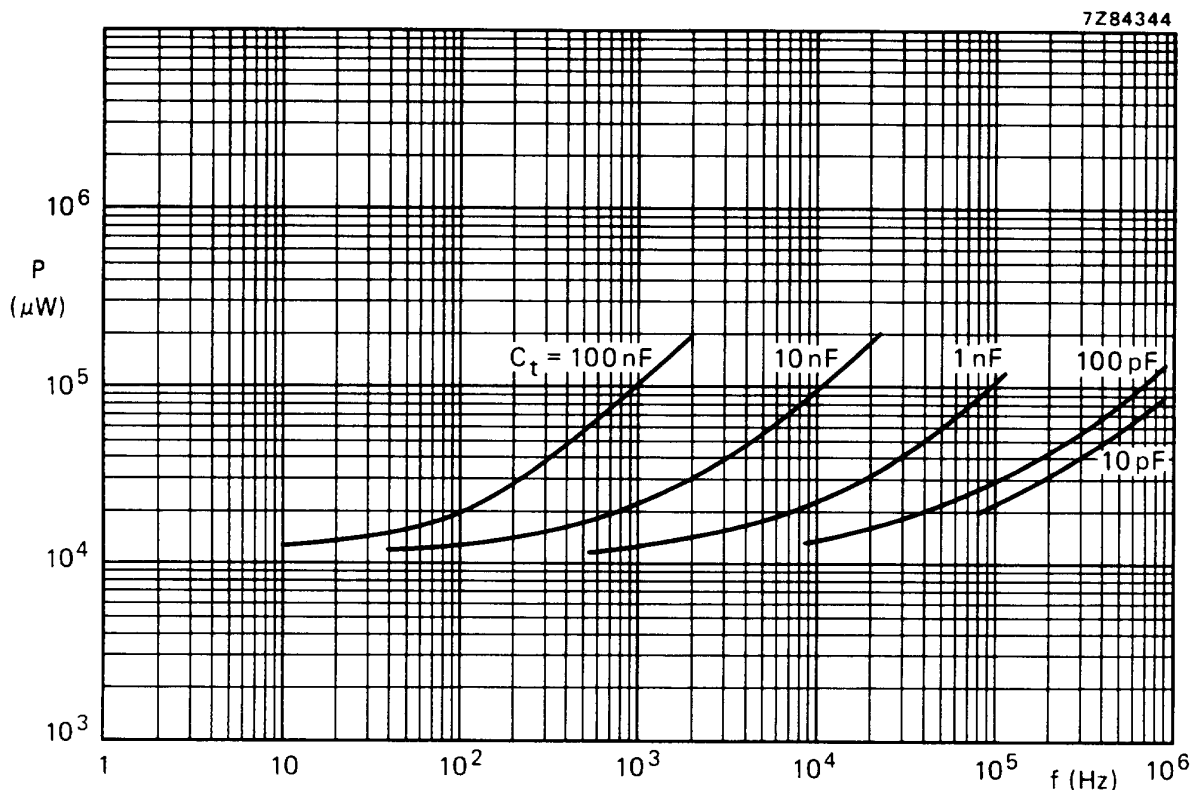

Fig. 12 Power consumption as a function of the output frequency at 0 or $\bar{0}$; $V_{DD} = 15\text{ V}$; astable mode.