

Limit switch in compact metal housing with terminal block







# ZC

The compact housing size and the terminal block with side facing cable exit allow the mounting where space is crucial and self-wiring connection is preferred. The rugged and tight housing construction provides high protection while the low-force actuators make the ZC limit switch ideal for switching smaller or lighter objects.

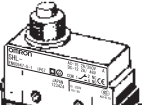
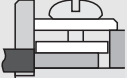
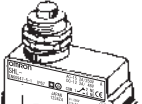
- terminal block for self-wiring with side facing cable exit
- low-force actuators for switching smaller or lighter objects
- rugged metal housing with IP67 protection
- wide portfolio range with optional features

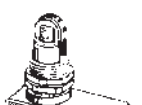

## Ordering Information

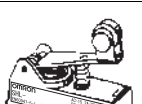
Actuator type		Connection method	Order code
	Plunger	  Terminal block with side facing cable exit (left/right changeable) for cables dia 8.5 to 10.5 mm <sup>*1</sup>	ZC-D55
	Plunger with M14 mounting		ZC-Q55
	Sealed roller plunger		ZC-N2255
	Roller plunger with M14 mounting		ZC-Q2255
	Sealed cross roller plunger		ZC-N2155
	Cross roller plunger with M14 mounting		ZC-Q2155
	Hinge lever - 50R		ZC-W55
	Hinge lever - 70R		ZC-W155
	Hinge roller lever - 50R		ZC-W255
	Hinge roller lever - 70R		ZC-W2155

\*1: Models with M20 conduit or other connection variations are available. Refer to OPTIONAL FEATURES for details

Model Number Legend

ZC-□55  
1

1. Actuator

- D: Plunger
- N21: Sealed cross roller plunger
- N22: Sealed roller plunger
- Q: Plunger with M14 mounting
- Q21: Cross roller plunger with M14 mounting
- Q22: Roller plunger with M14 mounting
- W: Short hinge lever
- W1: Hinge lever
- W2: Short hinge roller lever
- W21: Hinger roller lever

Other actuators are available (contact your OMRON representative for details and availability)

OPTIONAL FEATURES (contact your OMRON representative)

Cable connection and conduit

Standard in ZC Terminal block with screw fixing and snap-on rubber conduit cover for cables dia. 8.5 to 10.5 mm



Optional models A) Terminal block for soldering (pic 1) - standard is screw fixing (pic 2)

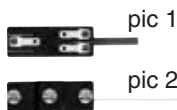

B) Cable breakage protection for cables dia 6 to dia 8mm



C) Terminal block with M20, PG13.5 or G1/2 conduit



D) Terminal block with dia 16 screw conduit cover for cables dia 5.8 to 7.6 mm



E) M12 connector



F) Pre-wired with 3 m VCTF S-flex cable



Mounting

Standard in ZC 2 parallel side mounting holes (see dimensions)

Optional models A) 2 diagonal side mounting holes

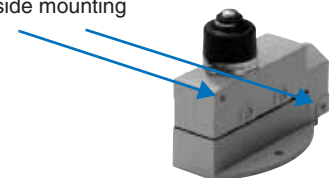

B) 2 base mounting holes

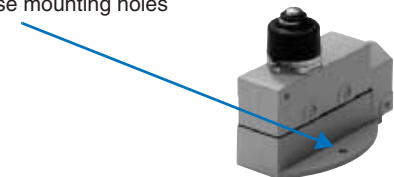

Electrical

Standard in ZC Loads >100 mA and >0.8 W  
0.5 A at 125 VDC (rating for non inductive load)

Optional models:A) Micro loads between 1mA to 100 mA and 0.8 W max.

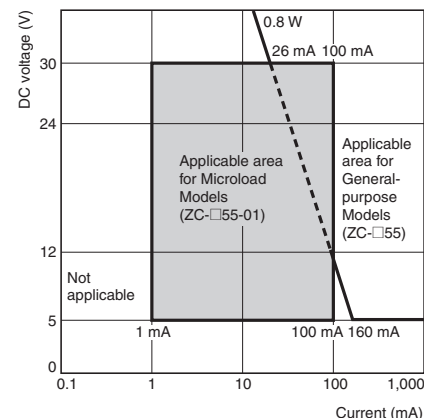

B) 10 A at 125 VDC high current switching at high DC voltage models (see table "Voltage and current rating for standard and types switching high currents at high VDC" on page 3)

C) Dual Contacts

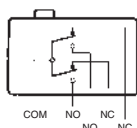

D) Maintained Contacts

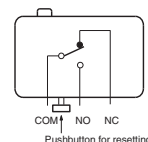

## Specifications

### Voltage and current rating

Voltage and current rating for standard and types switching high currents at high VDC

		Non-inductive load			Inductive load				Inrush current	
		Resistive load	Lamp load		Inductive load		Motor load		NC	NO
			NC and NO	NC	NO	NC	NO	NC		
Standard type	125 VAC	10	3	1.5	10		5	2.5	30 A	15 A
	250 VAC		2.5	1.25			3	1.5		
	8 VDC									
	14 VDC	3	1.5	6		5	2.5			
	30 VDC	6			5					
	125 VDC	0.5	0.4	0.4	0.05					
	250 VDC	0.25	0.2	0.2	0.03					
High current at high VDC switching type	8 VDC	10	3	1.5	10		5	2.5	30 A	15 A
	14 VDC									
	30 VDC									
	125 VDC				7.5	6				
	250 VDC	3	1.5	0.75	2	1.5	2	1.5		

### General specifications

Durability	Mechanical	10,000,000 operations min
	Electrical	500,000 operations min
Operating speed	Plunger	0.05 mm/s to 0.5 m/s
Operating frequency	Mechanical	120 operations / min
	Electrical	20 operations / min
Insulation resistance		100MΩ min (at 500VDC)
Contact resistance (initial)		15mΩ max
Dielectric strength		1,000 VAC, 50/60 Hz for 1 min between non-continuous terminals 2,000 VAC, 50/60 Hz for 1 min between each terminal and non-current-carrying metal part
Vibration resistance	Malfunction	10 to 55 Hz, 1.5 mm double amplitude <sup>1)</sup>
Shock resistance	Destruction	1,000 m/s <sup>2</sup> min
	Malfunction	300 m/s <sup>2</sup> min
Ambient temperature	Operating	-10°C to 80°C (with no icing)
Ambient humidity	Operating	35% to 95% RH
Degree of protection		IEC 60529: IP67

<sup>1)</sup> Less than 1 ms under a free state at the operating limits

### Additional specifications after EN60947-5-1 (TÜV Rheinland File No J50041904)

Category	AC-12 10A/250 VAC
Rated insulation voltage	1,000 VAC
Short circuit protective device	10A fuse type gG (IEC60269)
Protection against electrical shock	Class II

### Operating characteristics

Values for OF and RF are in N and values for PT, OT, MD and OP are in mm unless otherwise specified.

	ZC-D□	ZC-Q2□	ZC-Q5□	ZC-N2□	ZC-W1□	ZC-W21□	ZC-W25□	ZC-W5□
Operating force (OF)	11.8			6.86	2.75		3.92	
Release force (RF)	4.9			1.67	0.59		0.78	
Pre-travel (PT)	1.5				-			
Overtravel (OT)	2.4	3		2.5	8.4		6	
Movement differential (MD)	0.2				1.4		1	
Operating Position (OP)	32.4±0.8	47.4±0.8	38.2±0.8	47.4±0.8	28.5±1.2	43.0±1.2		28.5±1.2

## Dimensions

### General product set up

The cable exit direction can be changed by 180°.

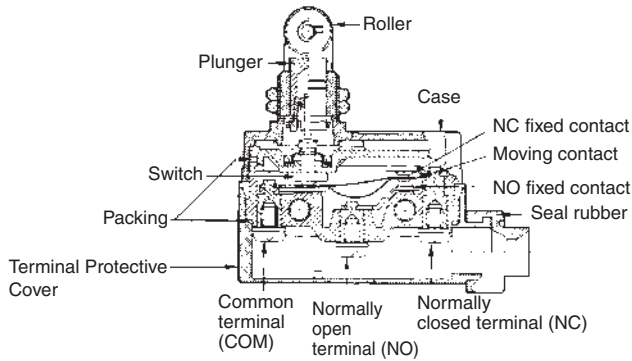

Example: ZC-Q2255

**Note:** M4 binding head screws (with toothed washers) are used as the terminal screws.

### Dimensions

**Note:** All units are in millimeters unless otherwise indicated.

#### ZC-D55

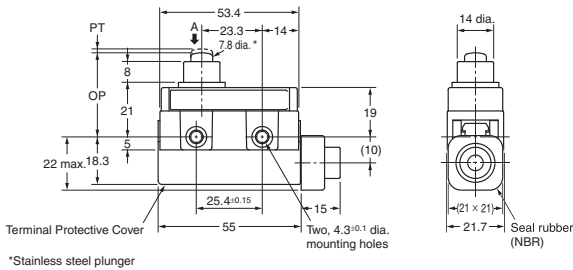

\*Stainless steel plunger

#### ZC-Q55

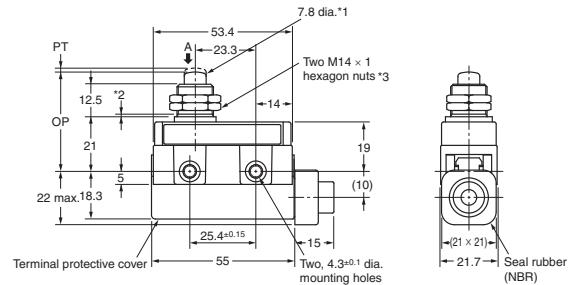

- \*1. Stainless steel plunger
- \*2. The length of the imperfect threads is 1.5 mm maximum.
- \*3. Thickness: 3 width: 17

**Note:** Do not use the M14 mounting screw and the case mounting hole at the same time.

#### ZC-Q2255

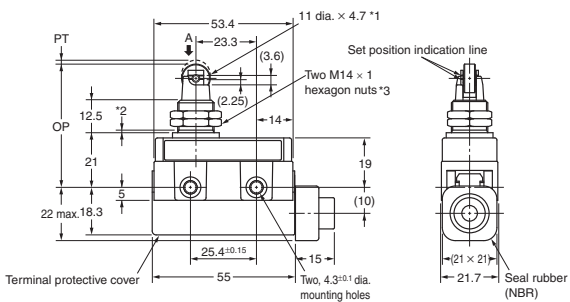

- \*1. Stainless sintered alloy roller
- \*2. The length of the imperfect threads is 1.5 mm maximum.
- \*3. Thickness: 3 width: 17

**Note:** Do not use the M14 mounting screw and the case mounting hole at the same time.

#### ZC-Q2155

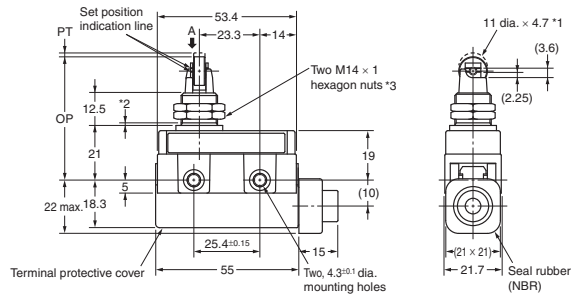

- \*1. Stainless sintered alloy roller
- \*2. The length of the imperfect threads is 1.5 mm maximum.
- \*3. Thickness: 3 width: 17

**Note:** Do not use the M14 mounting screw and the case mounting hole at the same time.

#### ZC-N2255

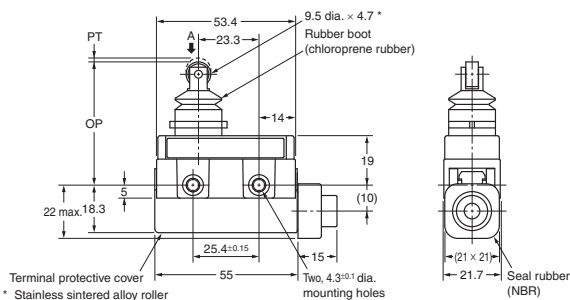

\* Stainless sintered alloy roller

#### ZC-N2155

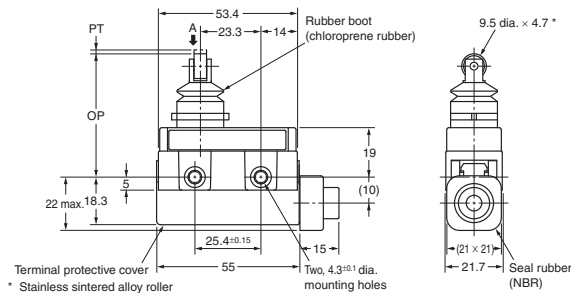

\* Stainless sintered alloy roller

**Note:** 1. Unless otherwise specified, a tolerance of  $\pm 0.4$  mm applies to all dimensions.  
2. Operating characteristics are for when the Switch is operated from direction A.

ZC-W55

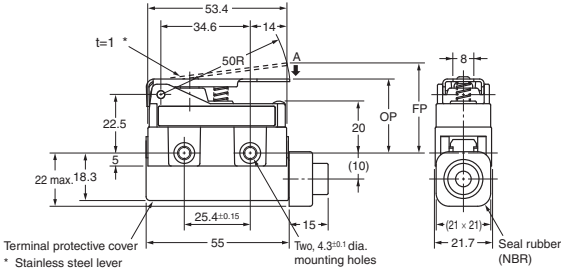

ZC-W155

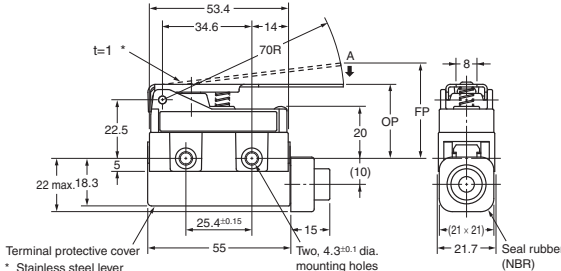

ZC-W255

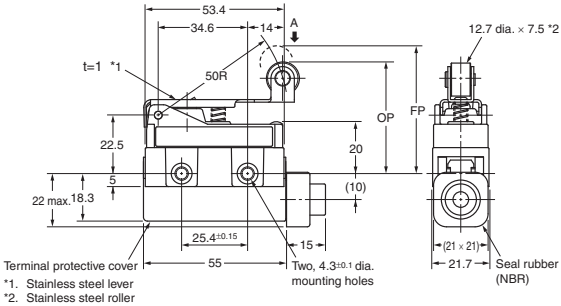

ZC-W2155

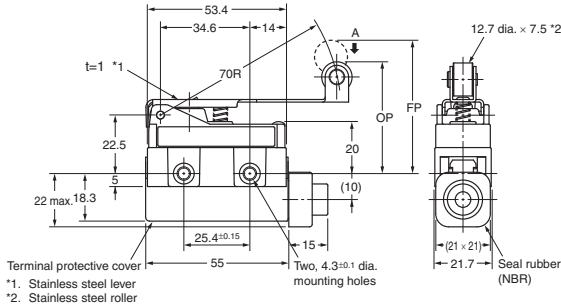

Note: 1. Unless otherwise specified, a tolerance of  $\pm 0.4$  mm applies to all dimensions.  
2. Operating characteristics are for when the Switch is operated from direction A.

**Precautions for Correct Use**

**Operating Environment**

- Seal material may deteriorate if a Switch is used outdoor or where subject to special cutting oils, solvents, or chemicals. Always appraise performance under actual application conditions and set suitable maintenance and replacement periods.
- Install Switches where they will not be directly subject to cutting chips, dust, or dirt. The Actuator and Switch must also be protected from the accumulation of cutting chips or sludge.



- Constantly subjecting a Switch to vibration or shock can result in wear, which can lead to contact interference with contacts, operation failure, reduced durability, and other problems. Excessive vibration or shock can lead to false contact operation or damage. Install Switches in locations not subject to shock and vibration and in orientations that will not produce resonance.
- The Switches have physical contacts. Using them in environments containing silicon gas will result in the formation of silicon oxide (SiO<sub>2</sub>) due to arc energy. If silicon oxide accumulates on the contacts, contact interference can occur. If silicon oil, silicon filling agents, silicon cables, or other silicon products are present near the Switch, suppress arcing with contact protective circuits (surge killers) or remove the source of silicon gas.

**Dog Angle**

When operating the roller type, be sure to set the dog angle to less than 30° (even when operating at a low speed). Operating the model at a dog angle exceeding 30° will soon cause abrasion or damage. Do not apply a twisting force to the plunger. Set the OT to 70% to 100% of the specified value so that the actuator will not exceed the OT.

**Handling**

- When detaching the Terminal Protective Cover, insert a screwdriver and apply a force in the opening direction. Do not use excess force to remove the cover. Doing so may cause deformation in the fitting section and reduce the holding force.
- When mounting the Terminal Protective Cover to the case, align the cover on the case and then press the cover down to mount it firmly. If the cover is pressed down in an inclined position, rubber packing will deform and thus affect the sealing capability.

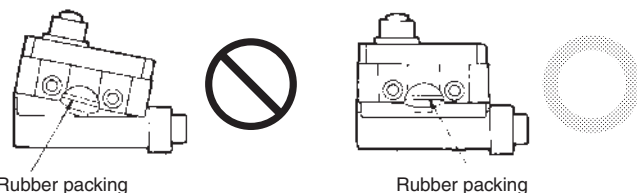
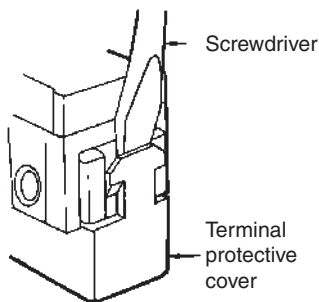

- A 8.5-dia. to 10.5-dia. cable can be applied as seal rubber for the lead wire outlet. (Use two- or three-core cable of VCT1.25 mm<sup>2</sup>.)
- Use weather-proof rubber (chloroprene rubber) as seal rubber for the ZC-N22(21)55.

**Mounting**

- When mounting the Switch with screws on a side surface, fasten the Switch with M4 screws and use washers, spring washers, etc., to ensure secure mounting.
- When mounting ZC-Q55, ZC-Q2255, or ZC-Q2155 with screws on a side surface, remove the hexagonal nuts from the actuator.

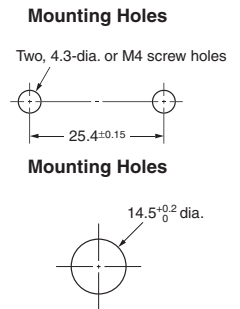

**Appropriate Tightening Torque**

A loose screw may result in a malfunction. Be sure to tighten each screw to the proper tightening torque as shown below.

No.	Type	Appropriate Tightening Torque
(1)	Terminal screw	0.78 to 1.18 N·m
(2)	Panel mounting screw	4.90 to 7.84 N·m
(3)	Side mounting screw	1.18 to 1.47 N·m

**Operation**

With the ZC-Q22(21)55, an appropriate OT line is marked on the plunger. Set the OT so that it is between the two X-surface lines.

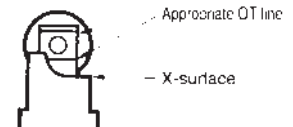



---

**WARRANTY**

OMRON's exclusive warranty is that the products are free from defects in materials and workmanship for a period of one year (or other period if specified) from date of sale by OMRON.

OMRON MAKES NO WARRANTY OR REPRESENTATION, EXPRESS OR IMPLIED, REGARDING NON-INFRINGEMENT, MERCHANTABILITY, OR FITNESS FOR PARTICULAR PURPOSE OF THE PRODUCTS. ANY BUYER OR USER ACKNOWLEDGES THAT THE BUYER OR USER ALONE HAS DETERMINED THAT THE PRODUCTS WILL SUITABLY MEET THE REQUIREMENTS OF THEIR INTENDED USE. OMRON DISCLAIMS ALL OTHER WARRANTIES, EXPRESS OR IMPLIED.

**LIMITATIONS OF LIABILITY**

OMRON SHALL NOT BE RESPONSIBLE FOR SPECIAL, INDIRECT, OR CONSEQUENTIAL DAMAGES, LOSS OF PROFITS OR COMMERCIAL LOSS IN ANY WAY CONNECTED WITH THE PRODUCTS, WHETHER SUCH CLAIM IS BASED ON CONTRACT, WARRANTY, NEGLIGENCE, OR STRICT LIABILITY.

In no event shall responsibility of OMRON for any act exceed the individual price of the product on which liability is asserted.

IN NO EVENT SHALL OMRON BE RESPONSIBLE FOR WARRANTY, REPAIR, OR OTHER CLAIMS REGARDING THE PRODUCTS UNLESS OMRON'S ANALYSIS CONFIRMS THAT THE PRODUCTS WERE PROPERLY HANDLED, STORED, INSTALLED, AND MAINTAINED AND NOT SUBJECT TO CONTAMINATION, ABUSE, MISUSE, OR INAPPROPRIATE MODIFICATION OR REPAIR.

**SUITABILITY FOR USE**

THE PRODUCTS CONTAINED IN THIS DOCUMENT ARE NOT SAFETY RATED. THEY ARE NOT DESIGNED OR RATED FOR ENSURING SAFETY OF PERSONS, AND SHOULD NOT BE RELIED UPON AS A SAFETY COMPONENT OR PROTECTIVE DEVICE FOR SUCH PURPOSES. Please refer to separate catalogs for OMRON's safety rated products.

OMRON shall not be responsible for conformity with any standards, codes, or regulations that apply to the combination of products in the customer's application or use of the product.

At the customer's request, OMRON will provide applicable third party certification documents identifying ratings and limitations of use that apply to the products. This information by itself is not sufficient for a complete determination of the suitability of the products in combination with the end product, machine, system, or other application or use.

The following are some examples of applications for which particular attention must be given. This is not intended to be an exhaustive list of all possible uses of the products, nor is it intended to imply that the uses listed may be suitable for the products:

- Outdoor use, uses involving potential chemical contamination or electrical interference, or conditions or uses not described in this document.
- Nuclear energy control systems, combustion systems, railroad systems, aviation systems, medical equipment, amusement machines, vehicles, safety equipment, and installations subject to separate industry or government regulations.
- Systems, machines, and equipment that could present a risk to life or property.

Please know and observe all prohibitions of use applicable to the products.

NEVER USE THE PRODUCTS FOR AN APPLICATION INVOLVING SERIOUS RISK TO LIFE OR PROPERTY WITHOUT ENSURING THAT THE SYSTEM AS A WHOLE HAS BEEN DESIGNED TO ADDRESS THE RISKS, AND THAT THE OMRON PRODUCT IS PROPERLY RATED AND INSTALLED FOR THE INTENDED USE WITHIN THE OVERALL EQUIPMENT OR SYSTEM.

**PERFORMANCE DATA**

Performance data given in this document is provided as a guide for the user in determining suitability and does not constitute a warranty. It may represent the result of OMRON's test conditions, and the users must correlate it to actual application requirements. Actual performance is subject to the OMRON Warranty and Limitations of Liability.

**CHANGE IN SPECIFICATIONS**

Product specifications and accessories may be changed at any time based on improvements and other reasons.

It is our practice to change model numbers when published ratings or features are changed, or when significant construction changes are made. However, some specifications of the product may be changed without any notice. When in doubt, special model numbers may be assigned to fix or establish key specifications for your application on your request. Please consult with your OMRON representative at any time to confirm actual specifications of purchased products.

**DIMENSIONS AND WEIGHTS**

Dimensions and weights are nominal and are not to be used for manufacturing purposes, even when tolerances are shown.

**ERRORS AND OMISSIONS**

The information in this document has been carefully checked and is believed to be accurate; however, no responsibility is assumed for clerical, typographical, or proofreading errors, or omissions.

**PROGRAMMABLE PRODUCTS**

OMRON shall not be responsible for the user's programming of a programmable product, or any consequence thereof.

---

**OMRON EUROPE B.V.**

Wegalaan 67-69,  
 NL-2132 JD, Hoofddorp,  
 The Netherlands  
 Phone: +31 23 568 13 00  
 Fax: +31 23 568 13 88  
 www.industrial.omron.eu