

This is a controlled document.

Hardcopy to be endorsed by authorized person.

Check with Issuing Office or SAP system for latest update.

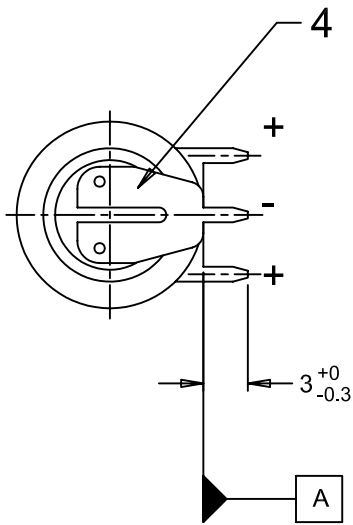
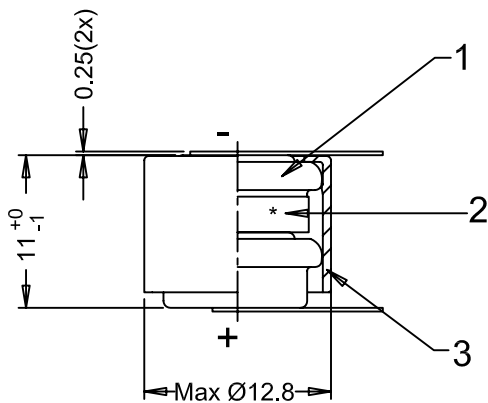
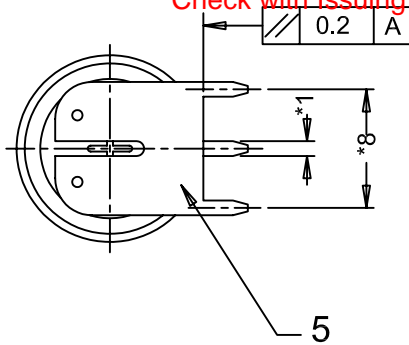

Note: * Dimensions for reference only

No.	Alterations:	Date:	Name:	Dimensions in mm	Material:
1	AO 20/02; Single PC tag fm 013415 to 078650 & remove +ve sign	2002-01-31	Yeni	Tolerance: As specified	Refer to part list no: 070964
				Projection:	Description: 2/V40H battery with snap-on plastic casing & solder tags
			Scale: 2 : 1		
			Loc. : 1	Date: Name:	
			Prepared: 1997-11-04	C.Y.LEE	
			Approved:		
RIGHTS RESERVED TO MAKE TECHNICAL CHANGES, AS A RESULT OF FURTHER DEVELOPMENT, WITHOUT NOTICE. THIS DRAWING IS THE PROPERTY OF VARTA BATTERIES PTE LTD AND MUST NOT BE COPIED OR DISCLOSED TO A THIRD PARTY WITHOUT THE WRITTEN CONSENT OF VARTA BATTERIES PTE LTD.					Dwg. No: 070964
					VKB Order No: 55604 602 059
					Released : 2002-01-31
					4 0 1